

### This package includes:

- (1) IDS Series Pedestal Controller
- (1) Mounting Template and hardware
- (1) Instruction Sheet
- (2) Keys

### Tools/supplies required (not included):

- Medium Standard screwdriver
- Small Standard screwdriver
- 9/16", 7/16", 11/32" Sockets
- Wire Stripper, Wire nuts, DBR-6 waterproof connectors or equivalent (for all two-wire path connections)

### Select a location for installation of the controller based on these factors:

1. Availability of 115VAC power (see specifications Electrical Data below).
2. Do not locate under overhanging branches of trees or any structure that may attract lightning.
3. Avoid locations where sprinklers spray upward onto controller, and low areas subject to flooding.
4. Locate controller in a central location of all the valves/sprinklers that it controls in order to maintain visible operation and reduce wire lengths/costs.

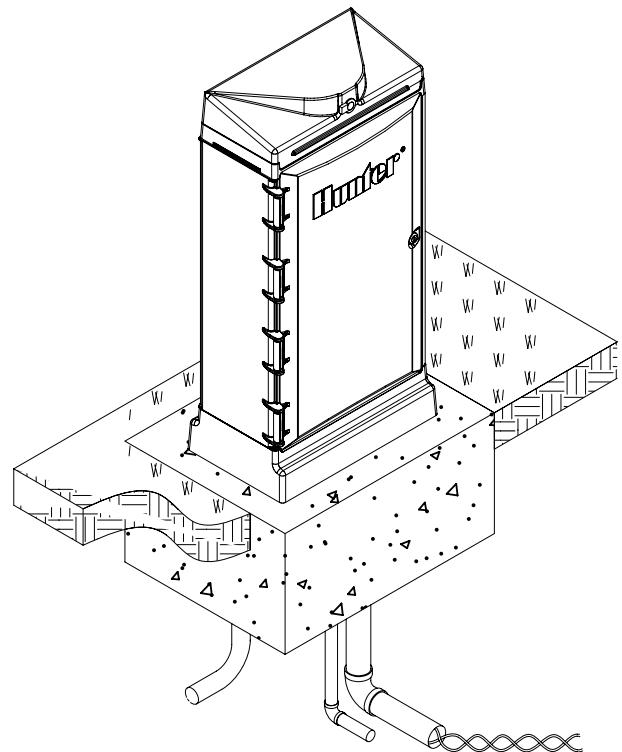

### Electrical Data for Pedestal and Wall-Mount Controllers

Primary (input)	U.S. and Canada International	105 to 125 VAC, 50/60 Hz	1 Amp maximum
Secondary (outputs)	Transformer	28 VAC, 50/60 Hz	2 Amp maximum

### Concrete Base Installation:

1. Set forms for a 13" (330mm) wide x 20" (508) long x 12" (305mm) deep concrete base. The base pad should be 2" (50mm) above grade for proper drainage.
2. Position a 3" (76mm) diameter conduit sweep elbow for the two-wire decoder paths and a 1" (25mm) diameter conduit sweep elbow for the power supply in the framed area and secure so they will enter the bottom of the controller correctly.

**Note:** The AC power conduit is positioned differently for plastic or stainless steel pedestals... position the sweep for the correct pedestal type, as labeled on the base template (see illustration).

3. Allow at least 6" of conduit above the surface of the concrete pad for the AC power conduit. Cover both ends of the conduit to keep debris out.
4. Shape the concrete base to shed water away from the controller. Assemble the J-bolts nuts and washers on the template (allow a minimum of 3/8" or 9.5mm protruding above each nut).
5. Verify that the word "FRONT", molded into the top of the template, is oriented correctly (the keypad will face this direction when the controller is installed). Work the J-bolts down into the concrete until the template sits level on top of the concrete. Smooth and allow the concrete to cure (at least 24 hours).

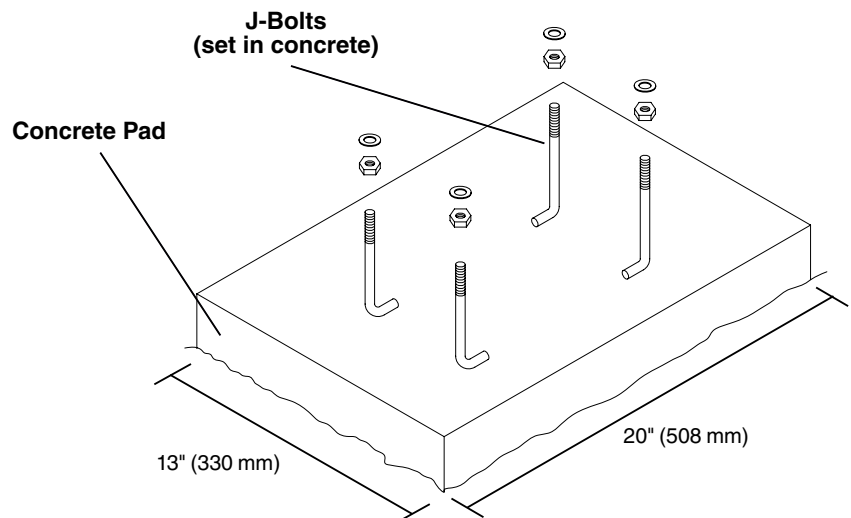
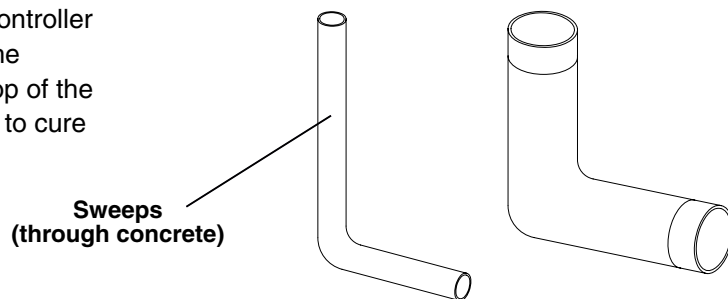
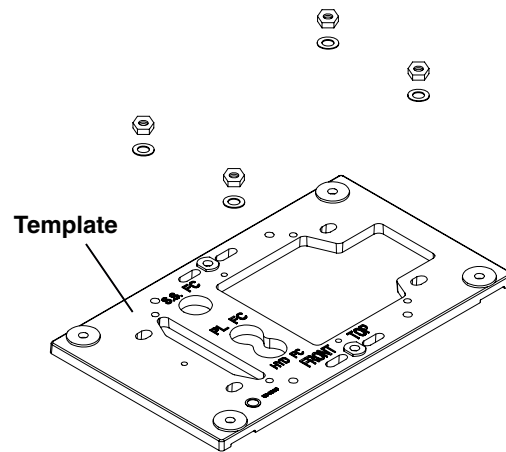
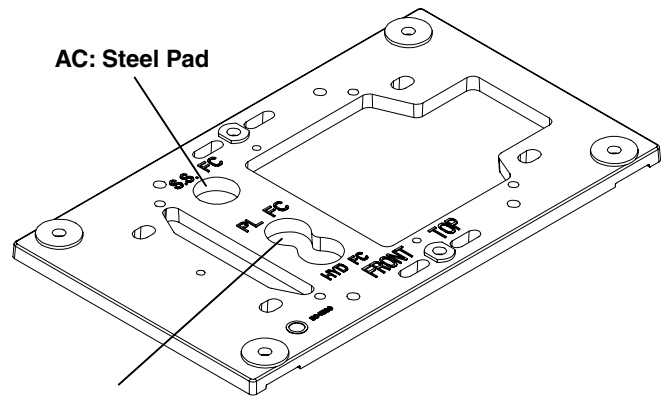

**Note:** It is very important with plastic pedestals to insure a smooth mounting surface. Uneven surfaces may cause the pedestal shape to distort, preventing proper sealing of the doors.

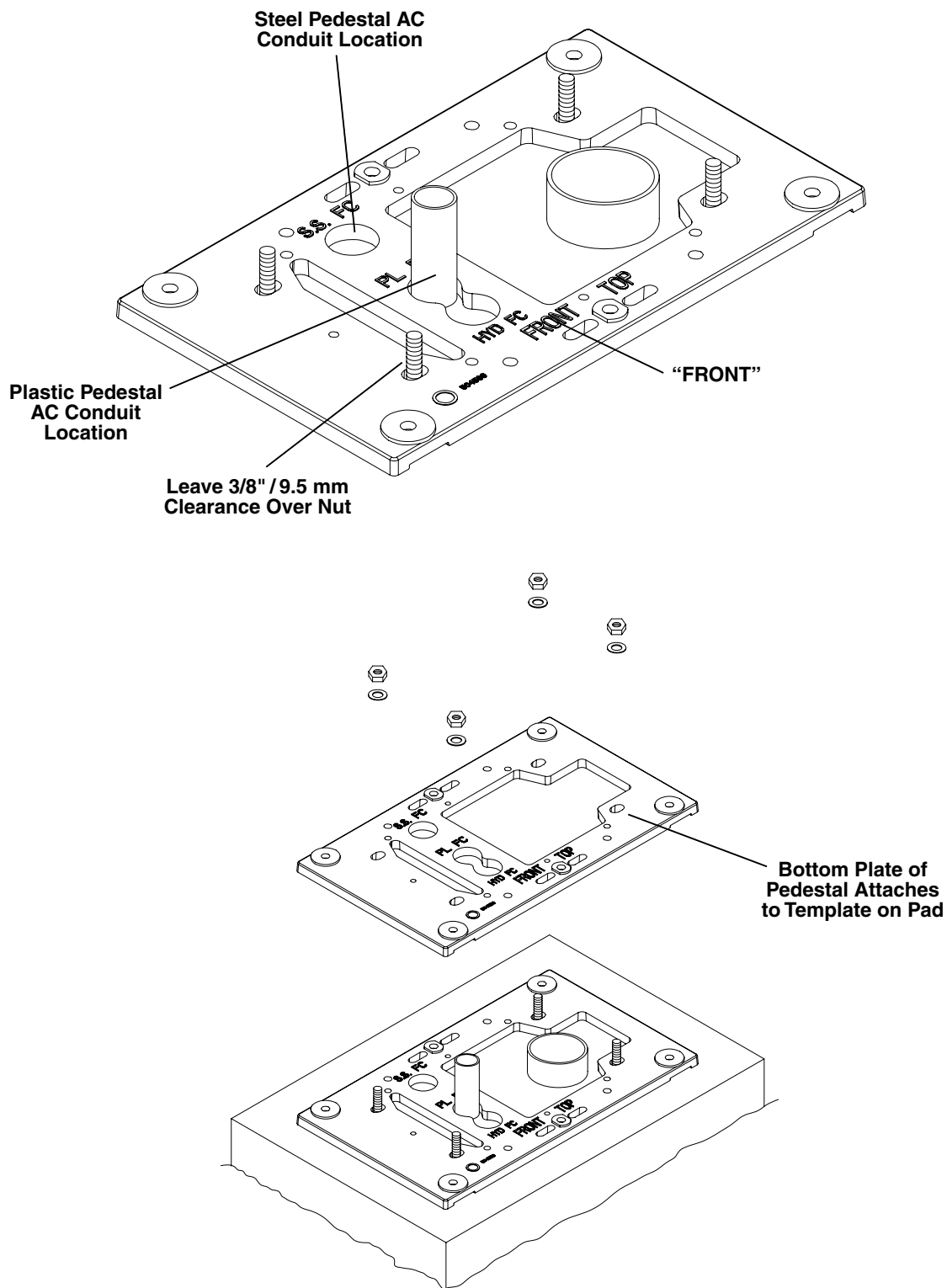

### Controller Installation

1. Observe NEC and local electrical codes in all controller wiring.
2. Remove the 9/16" nuts and washers from the concrete base. Place the controller over the template, sweeps, and bolts, and secure with the nuts and washers.
3. Install a 5/8" (16mm) dia. x 8' (2.5m) copper clad ground rod and/or plate approximately 8' (2.5m) away from the controller, at right angles to, or as far from the two-wire path(s) as possible. Attach a 6 AWG (13.3mm<sup>2</sup>) solid copper ground wire to the ground lug (on the backplane inside the controller), route it through the large conduit and connect the other end to the ground rod, using a brass or copper clamp (see Earth Grounding section, below).
4. Turn off AC power at the source and verify that it is off with an AC voltmeter before proceeding.
5. Remove the transformer wiring cover in the controller (11/32" socket). Secure the conduit to the inside base of the transformer wiring compartment with approved electrical conduit fittings.
6. Insert the 3 power wires through the small conduit and connect to the mating wires of the transformer assembly (with approved power wire connectors), observing the appropriate color code:

Wire	Color
Neutral	White
Hot	Black
Ground	Green

7. Replace the transformer cover, and apply AC power to the controller and verify proper operation (see Operations Manual for detailed instructions).

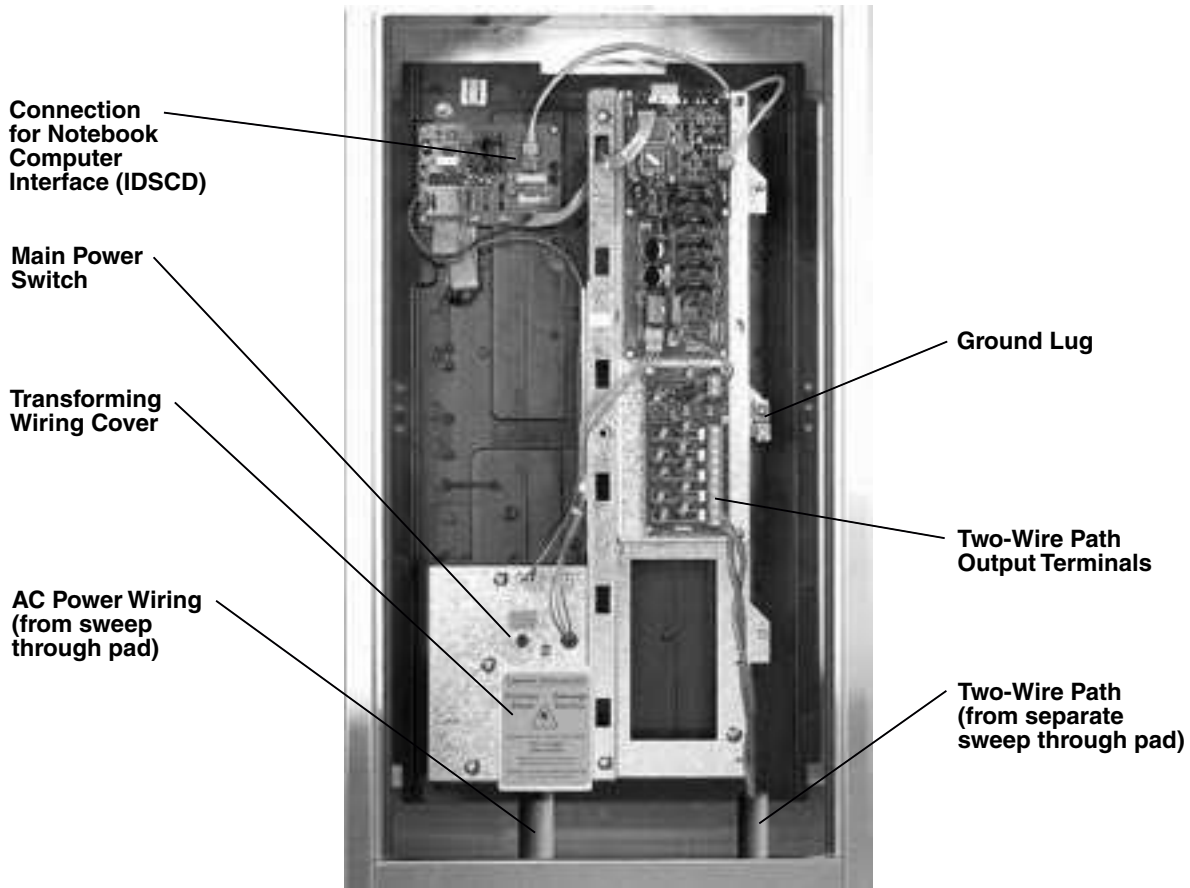

### Two-Wire Path Connections:

IDS decoder systems consist of field controllers, or consoles, with up to 5 two-wire “paths” which generally follow the valves and sprinklers throughout the installation. Individual decoders or 4-station decoders are spliced into the path, or paths, wherever solenoid control is desired. The solenoids receive their power over the same two-wire paths that carry the activation signals.

The Output Board for an IDS system has 5 surge-protected outputs with two terminals for each path.

IDS systems must be wired with IDWIRE1 or IDWIRE2 cable, which is color-coded Red and Blue. Each decoder and surge suppression device also has Red and Blue wires; generally, connect the Red wire from the device to the red wire in the path, and the Blue wire from the device to the blue wire in the path. In-line surge suppressors (GVIKLSPN) have a red-and-blue pair on each end, one pair for the upstream connection, and one pair for the downstream connection.

Consult the individual system specification drawings for your system to identify the paths from each field controller.

Insert the Red-and-Blue IDWIRE path wires through the large conduit opening in the base of the controller template, extend the wires through the hole to the top of the controller, and cut off at that length.

Locate the appropriate terminals on the output board for the wire path (see numbers next to terminal strip). Loosen the screws for the terminals to be connected with a small screwdriver.

Strip approximately ½" (13mm) of the insulation from the end of each of the wires, and insert into the aperture on the side of the terminal strip. Connect each wire to its place on the terminal strip (do not overtighten).

Each output used will have one red wire and one blue wire, but it does not matter which color goes to which of the two terminals for the path (it is advisable to alternate red and blue uniformly if there are multiple paths).

IDS Output Board

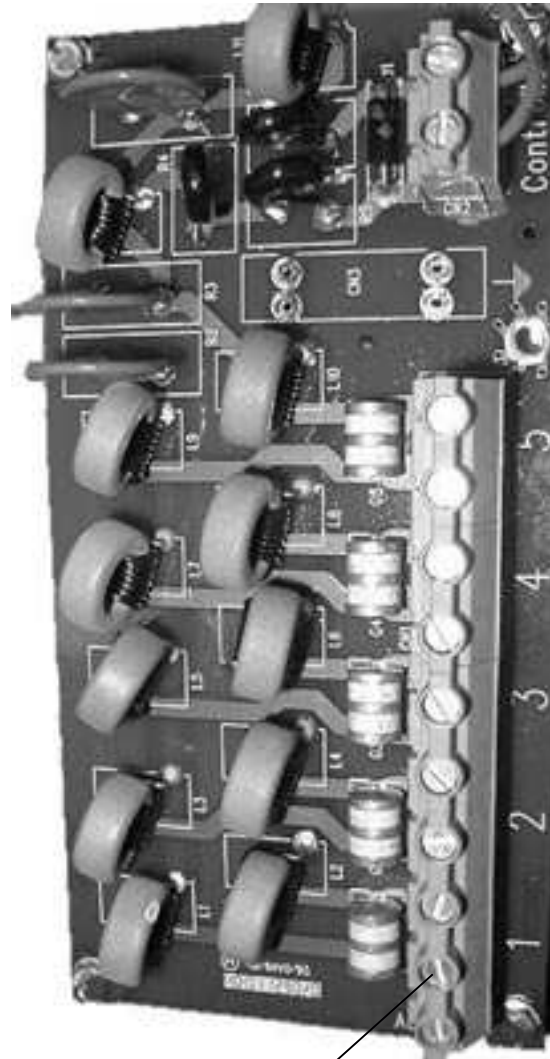

Wire Path Connections

### Decoder/Valve Connections:

The general idea of a decoder system is to have one decoder (ID1) for each solenoid (valve or head) and to have it close to the solenoid. This gives maximum irrigation control, minimum wiring, easy installation and simple documentation. A single station ID1 may operate two solenoids to save cost, however.

When multiple solenoids are to be activated by one decoder, or the 4-station decoder (ID4) is to be used, cables need to be run between the decoder and all of the solenoids.

1. Decoders are to be installed in approved valve boxes.
2. Use approved high-voltage waterproof connectors for all wiring connections.
3. Put the decoder as close to the solenoids as possible, and use a twisted pair between the decoder and the solenoids.
4. Do NOT connect multiple solenoids together with a common. Always use one pair (2 cores) for each output from the multi-station ID4 decoder.
5. If 2 solenoids are to be fed from the same decoder output, either run 2 cables from the decoder to the solenoids, or go from the decoder to the first solenoid, and then to the second from the first.

In high lightning areas it is not recommended to have more than 100-150 ft (30-50m) cable lengths between decoder and solenoid. Longer lengths can be used, but it greatly increases the risk of lightning damage to the decoder and solenoids. Wire similar to IDWIRE1 cable is a good cable for solenoid runs, though a different color scheme for the wires should be employed to reduce confusion with the main Red-Blue two-wire path.

A maximum of 2 standard solenoids can be connected to a decoder output.

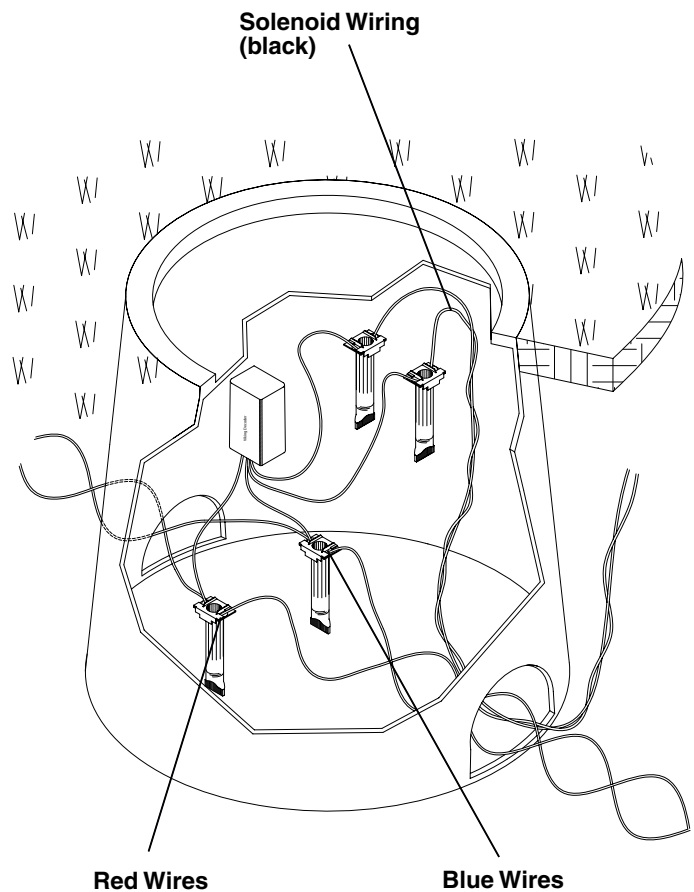

**ID1 Wiring**

The 4-station decoder can also have 2 solenoids per output, but only 4 solenoids may be active at the same time. All 4 outputs may have 2 solenoids each, as long as only 2 outputs are active at the same time. If more than 4 solenoids are activated, the decoder's internal fuse may trip and turn the decoder off. It will reset automatically when the decoder's power is cycled (turn station off, then back on).

A 104-station controller can handle a total of 20 active solenoids. This can be 20 decoders with one solenoid each, 10 decoders with 2 solenoids each, or any combination which does not exceed the capacity of a single decoder.

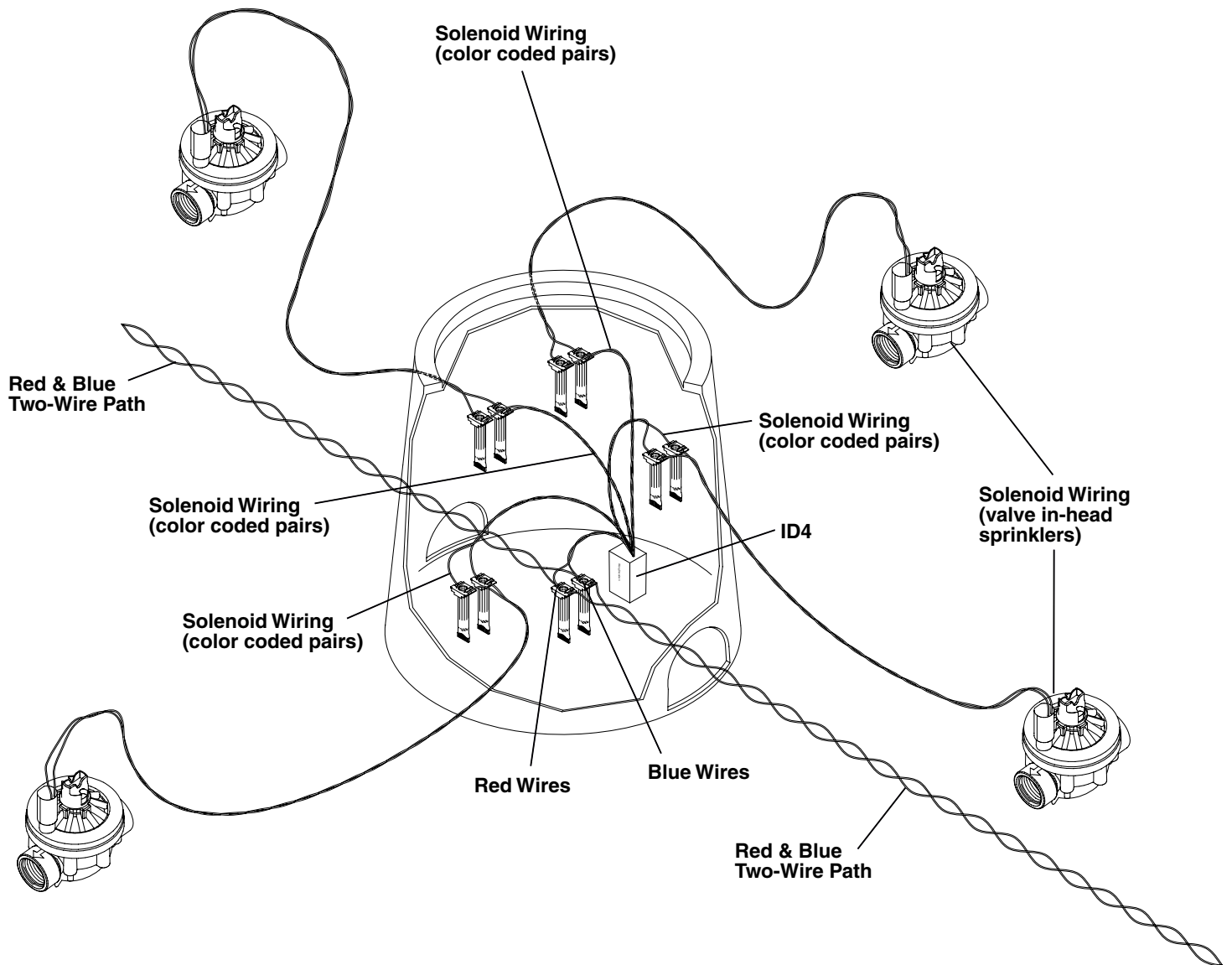

## Typical IDS Installation

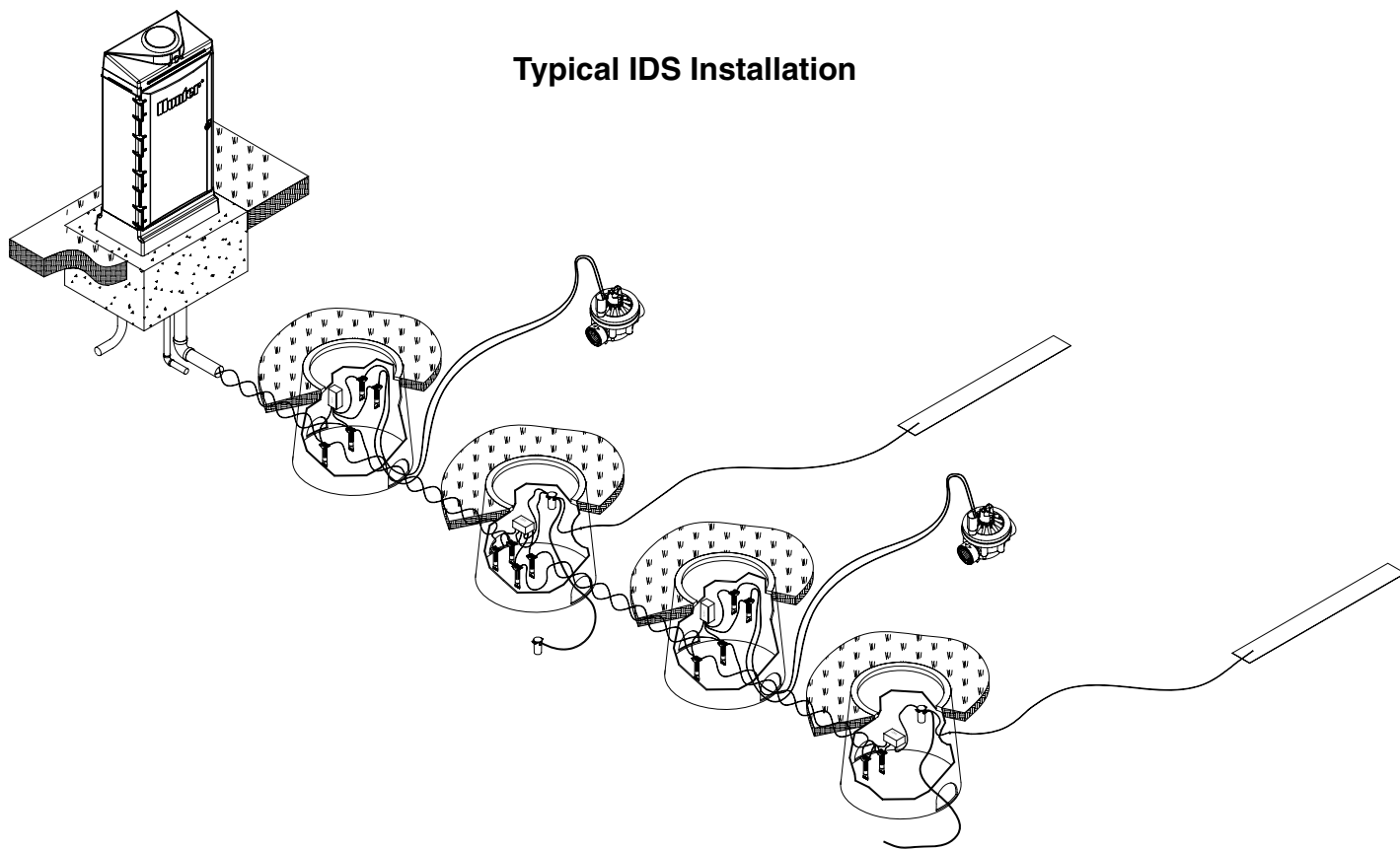

### Earth Grounding Hunter IDS Systems

The minimum recommended level of protection is to have one IDE End-line surge suppressor at the end of each field cable and one IDN In-line surge suppressor in the middle of each path longer than 4000ft. For higher levels of protection, put the IDN devices closer together, and use more 2-wire paths out from the controller.

The IDS controller itself shall be grounded and tested to an impedance of 10 Ohms or less.

It is important that both the controller and the surge protection devices are grounded to ground rods or plates with less than 10 Ohms resistance. The ground should always be measured with a ground resistance meter. The devices should be disconnected during this test. A “clamp on meter” can not be used since this is an isolated system. The ground should be tested regularly for resistance.

Surge protection devices wear out, and should be replaced when they might have been damaged. The device is a complex electronic part and it is not possible to fully test whether it is working 100%. Replace surge protection devices if there is any visible damage to the device, or if nearby decoders or controllers have been damaged.

An IDE should be placed on the end of each path, and on the ends of any branches that are longer than 100 feet. In some cases, the branch can be connected back to the “main” path again at another point to reduce the need for a surge protector. This can sometimes be the case on fairways. This is a “loop” but it is a very local one, and does not affect trouble-shooting much if documented.

It is the responsibility of the Contractor to ground all electrical equipment installed in relation to the irrigation control system. Grounding components will include, but not be limited to, the items described in the following paragraphs.

Use grounding electrodes that are UL listed or manufactured to meet the minimum requirements of the National Electrical Code (NEC).

For detailed information on earth grounding of irrigation components, refer to the American Society

of Irrigation Consultants Earth Grounding Guideline 100-2002 ([www.asic.org](http://www.asic.org)).

### Pump Relay/Master Valve Connection:

The Pump Relay/Master Valve output in a IDS System is the decoder assigned to Station # 0 (zero) in the IDSCD set up and diagnostic software, or the station labeled “Pump” in the field controller facepack display.

The decoder assigned to station # 0 is connected to an approved Pump Start relay (Hunter PSR series), and will be automatically switched on whenever a controller Program with “Pump” set to “Yes” is started.

Pump Start Relays have higher power consumption than standard valve solenoids and must be treated differently for reliable operation.

- Keep the decoder-to-relay wiring as short as possible.
- The Pump Relay decoder must be the model ID4 four-station decoder. Dedicate a single output to the pump start relay, and cap the unused output wires to prevent accidental shorting.
- Set the Power Factor for the Pump station output to “5”.

*Do not connect the decoder output directly to a pump. Use only approved 24 VAC relays for pump activation.*

### Programming Decoders Into the Field Controller

Once the controller is installed, it is necessary to program each station in the controller memory for the correct decoder S/N number.

Each IDS decoder has a unique 8-digit Serial Number (S/N) printed on a metallic tag on the side of the decoder. The ID4 multi-station decoder has 4 individual Serial Numbers, with the same first 7 digits, followed by 1, 2, 3, or 4, along with the color-code for each station output.

The procedure is to assign each station output from the controller to the correct 8-digit Serial Number, so that IDS knows which decoder to activate.

This may either be done from the controller keypad, or through the optional IDSCD Decoder Manager software kit, by plugging a laptop computer into the controller.

### To program decoders from the controller keypad:

All IDS controllers are capable of 103-station operation, plus a Pump output. All stations will program the same way. There are 2 settings for any station:

- The decoder Serial Number (S/N). Station setup consists of assigning the 8-digit serial numbers on each decoder's label to one of the controller stations.

The Power Factor Level setting in the controller for each decoder controls how much power the solenoid gets. It is rarely necessary to change from its default value (2). For Pump Start Relays (see below), "heavy duty" solenoids, or solenoids very far away from the controller, it may be necessary to increase the Power Factor if the solenoid does not activate with a setting of 2.

The Power Factor for each decoder may be changed if necessary with either the IDSCD software, or from the keypad on the field controller console (Options, Edit Decoders). **CAUTION:** More is not always better. Increasing the Power Factor unnecessarily may deprive other decoders of power to activate solenoids. "2" is almost always adequate!

Press the Options key repeatedly (about 7 times) until Edit Decoders? appears in the display. Press Enter. The display will then show:

**Sta Pump Pwr 2**  
**S/N <90000000>**

...if the controller is unprogrammed. Otherwise, the S/N number will equal the S/N of the decoder assigned to the Pump. The cursor will be under the word Pump.

Technically, the Pump output is station number "0". A Pump decoder can start a Master Valve, or can be connected to a Pump Start Relay to start a Pump. If you are not using the Pump output from the controller,

skip the Pump by just pressing the Stations button, and the display will advance to station 1:

**Sta 001 Pwr 2**  
**S/N <90000000>**

- To select a different station to program, simply press the station button
- OR, use the Next key to move the cursor under the station number, type in a new number, and press Enter.

In most installations, you simply press the Stations button to display the station you want to set up. The cursor will appear under the S/N number.

Type the S/N for the appropriate decoder, and press Enter. Then press the Stations button again to advance to the next station, and repeat until all station/decoder assignments have been programmed. Generally, you will leave the Power Factor (Pwr) setting at "2".

When you are in Edit Decoder mode, you can also use the Next key to move the cursor around through the 3 positions in the display: The station number, the Power Factor, and the S/N. You may type the number you want at each position, and press Enter.

Use the Back button to move to the previous station.

If you only need to edit a specific station, type a station number at the "Sta" position, and press Enter, to go directly to that station.

Continue entering station decoder data until complete, and then press Exit to exit the Edit Decoder mode. The display will ask:

**Save Changes?**  
**YESIno**

Press Enter, with Yes capitalized, to save (then you may Exit again to return to standby mode). If you don't want to save the changes, press the Toggle key to capitalize No, and press Enter.

You may also clear the decoder S/N. Use the Stations key (or type the Station number) to go to the station you want to clear. To clear the decoder S/N for that

station, make sure that the cursor is under the S/N, and press the Clear key. The S/N will return to "90000000". Press Exit, and press Enter at the "Save Changes?" display.

If you are programming a large number of stations, the display may occasionally show "Data Saved!" as you advance through the stations (meaning the data is being automatically stored).

**Note:** Station decoder data is NOT erased when a Cold Start is performed on the controller (see Controller manual).

**LineOn/LineOff/Line Fault:** When the controller power is turned back on after setup, you should see the "Line On" display after a few seconds. "Line On" shows that power is present on the two-wire path(s), and will show the current draw in milliamps. This is the normal operating mode.

"Line Off" indicates a potential problem with the decoder output. It means that the controller facepack is functioning, but that no power is being sent out on the two-wire path(s). Try cycling the controller power off, and then back on (with the power switch), to get the transmitter to reset.

"Line Fault" indicates that the controller was outputting 2 or more amps, but no stations were running (the Line Fault message indicates that the controller has already shut line power down). This could indicate a break in the line, or a short between two wires. Troubleshoot the two-wire path.

**To use the IDSCD Decoder Manager software,** you must have a laptop computer with the software installed, and the special interface cable supplied with the IDSCD.

### **IDSCD (Decoder Manager) Program Installation:**

1. Start Windows on a laptop computer, and insert the IDSCD in the CD drive.
2. Select RUN option from the Taskbar Start menu if the setup installation does not begin on its own.

Follow Setup Wizard instructions. Defaults are recommended.

The serial interface cable which came with the IDSCD software will connect the laptop computer to the telephone-style jack on the IDS CPU board. To connect:

1. Turn controller power off.
2. Plug the 9-pin connector on one end of the cable to the serial port on the computer.
3. In the field controller, locate the RJ-45 telephone style jack on the IDS CPU board (see illustration above).
4. Disconnect the RJ-45 connector already there, and connect the RJ-45 end of the cable to the field controller. Turn controller power back on.

Select the Decoder Manager program from the program menu. Start the program and the configuration screen will appear. First click on FILE and COM SETUP in the dropdown menu. Select the COM port on your computer that will be connected via the modular jack to the IDS CPU board in the IDS Field Controller.

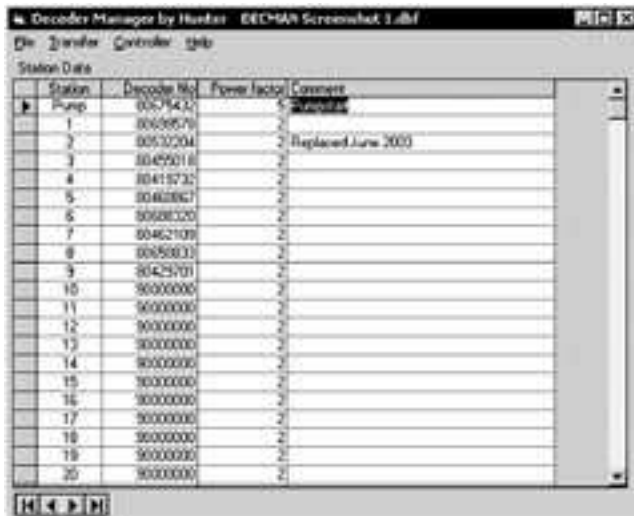

The screenshot shows a window titled "Decoder Manager by Hunter - EECMAN Screenshot 1.tif". Below the title bar is a menu bar with "File", "Transfer", "Controller", and "Help". The main area is a table with the following columns: "Station", "Decoder No.", "Power Factor", and "Comment". The table contains 20 rows of data, with the first row highlighted. The first row is for "Pump" with a "Decoder No." of "0007142" and a "Power Factor" of "2". The second row has a "Decoder No." of "0000079" and a "Power Factor" of "2". The third row has a "Decoder No." of "0000204" and a "Power Factor" of "2", with a "Comment" of "Replaced June 2003". The remaining rows have "Decoder No." values from "0000018" to "0000000" and "Power Factor" values of "2".

Station	Decoder No.	Power Factor	Comment
Pump	0007142	2	
1	0000079	2	
2	0000204	2	Replaced June 2003
3	0000018	2	
4	0041572	2	
5	0040867	2	
6	0000020	2	
7	00462109	2	
8	0005003	2	
9	00429701	2	
10	0000000	2	
11	0000000	2	
12	0000000	2	
13	0000000	2	
14	0000000	2	
15	0000000	2	
16	0000000	2	
17	0000000	2	
18	0000000	2	
19	0000000	2	
20	0000000	2	

Next, go to the main screen and view the columns showing "Station #, Decoder #, Power Factor and Comment".

Start by highlighting the pump or station 1 area in the Decoder column and enter in the decoder serial number. You can find the 8 digit number located on the lower left hand corner of the decoder's metallic label.

The Power Factor column allows for specialized power applications such as weak power strength at decoders located near the ends of long runs, decoders running in groups, simultaneously or for systems with deteriorating cable splices. Each decoder can be assigned a power factor rating from 1 – 5 with 5 being the highest power supplied. The software defaults to 2 if not user defined. There is a space to the right "Comment", for a description of the decoder location ie; Green #6, or First head on fairway #9, etc.

When all decoder serial numbers are entered click on the **FILE** dropdown menu and click **SAVE AS**. Assign a name to the file and save.

Next, click on **TRANSFER** and send assigned serial numbers to the controller. Note, **RECEIVE** is for downloading and viewing decoder assignments existing in each controller.

The **CONTROLLER** menu has three features for test and service.

The **MONITOR & TEST** allows for the verification of line current and status on each two-wire cable leg.

This dropdown menu also allows for manual activation of a decoder with amperage draw verification.

The **LOG TRANSMISSION** allows for a verification of activity throughout the irrigation cycle.

The **VIEW LOG** provides for viewing logged information from Monitor and Test.

When programming is complete, turn controller power off, disconnect the computer serial interface cable from the RJ-45 connector. Reconnect the original RJ-45 from the Power Supply Board to the **IDS CPU** board and turn controller power back on.