

I-20 *Ultra* Rotors

*Premium Quality Rotors for
Residential and Light Commercial Applications*

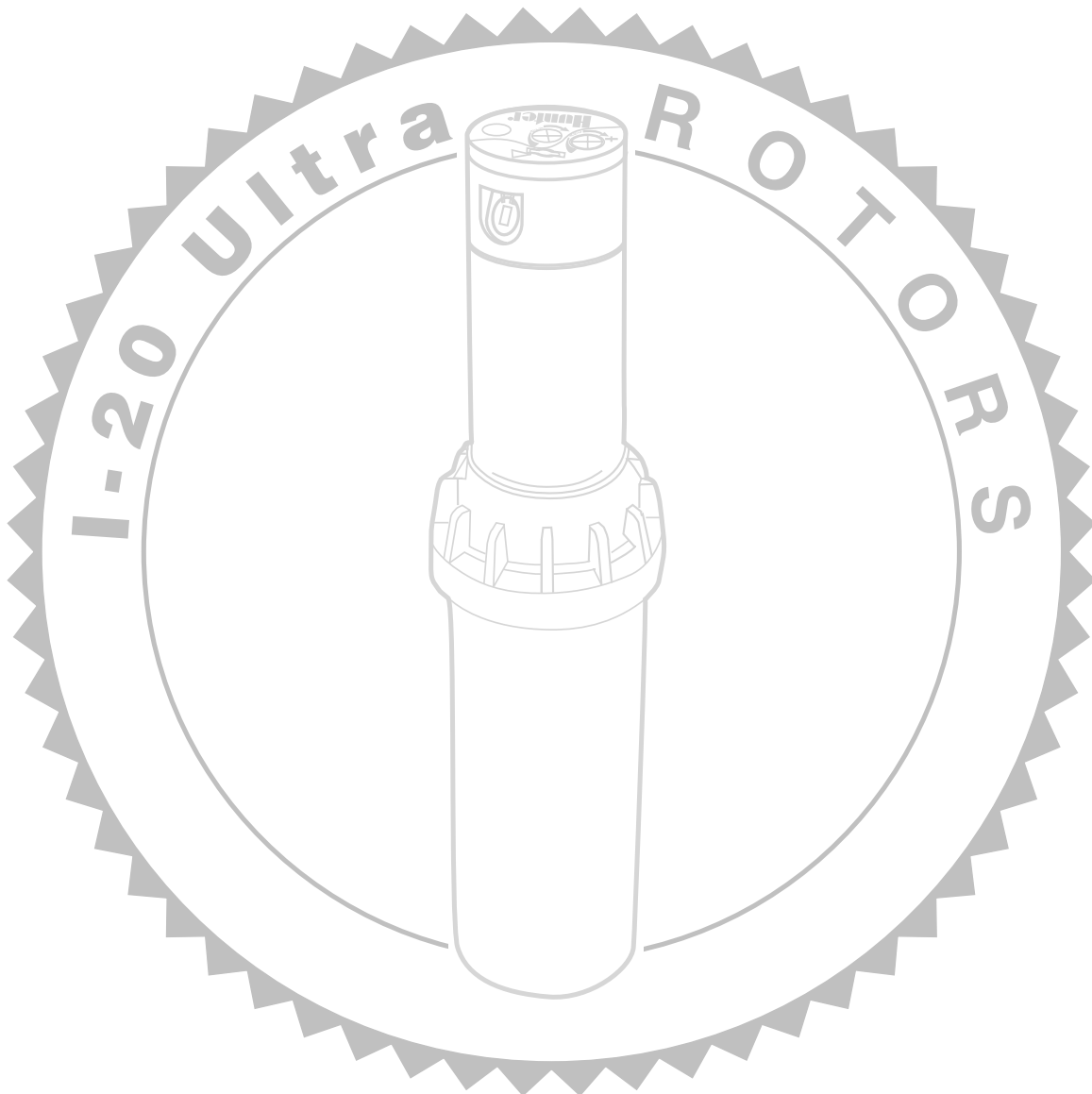

TABLE OF CONTENTS

Product Overview 1

Product Features and Benefits 2

Technical Information..... 7

Product Comparisons..... 8

Nozzle Replacement Guide 9

Product Explanation..... 9

Product Performance 10

Installation Details 12

Shrub Staking Installation..... 14

Installation and Adjustment Guide 15

I-20 *Ultra* Replacement Parts 18

Precipitation Rate and Sprinkler Run Time Formulas 20

PRODUCT OVERVIEW

The world's best gear-driven rotary sprinkler for residential and light commercial irrigation just keeps getting better. Hunter began setting the standards for professional gear-driven rotors two decades ago and continues to set the bar higher with each new enhancement to such proven reliable performers as the I-20 *Ultra*, our heavy duty, commercial grade workhorse for residential and light commercial irrigation.

The rotor's signature feature is the revolutionary FloStop® control which allows you to stop the flow of water through an individual head while the remainder of the zone is operating. The I-20 also offers one of the widest selections of nozzle choices in a rotary sprinkler. In addition to a full rack of 8 standard and 4 low angle nozzles, Hunter also offers 10 specialty nozzles. These include 6 short distance (smaller radius) nozzles and 4 high flow nozzles. All of these nozzles offer fast, simple installation and provide superior close-in coverage.

As if performance wasn't enough, the I-20 *Ultra* also boasts exceptional safety features, highlighted by an integral rubber cover that stays put to keep play areas safe. The rotor's small exposed surface area, combined with the softness of the rubber cover, makes it the preferred rotor choice for play areas. But, by no means is this a "soft" rotor. Areas subject to heavy foot traffic or equipment will meet their match in the extremely tough body cap with ribbed reinforcement. And, for additional toughness and durability, there's Hunter's optional stainless steel riser sleeve.

In addition, for those who prefer to maintain a higher cut of turf on their landscapes, the I-20 *Ultra* offers a 6-inch version. You'll get better clearance over the lawn while receiving the same degree of top-notch performance (as well as Hunter's unsurpassed 5-year warranty) found in all other models of the I-20. It's a level of performance that has earned the rotor its well-deserved reputation for quality.

If you are looking to upgrade over a typical residential grade rotor, this is where the search ends. No other rotor in its class gives you more.

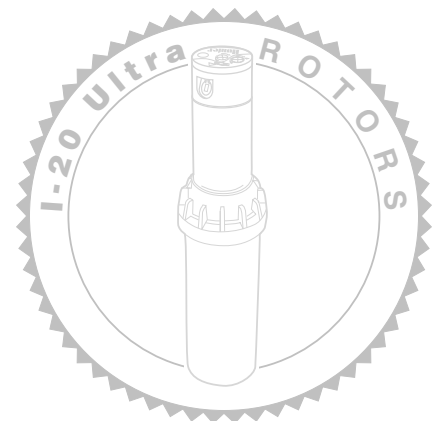

PRODUCT FEATURES AND BENEFITS



Six Rotor Models...

Shrub, 4", 6" and 12" pop-up

The Hunter I-20 *Ultra* comes in two turf heights, the 4" (10 cm) and 6" (15 cm) pop-up models, along with the 12" (30 cm) high-pop model, and the I-10 riser-mounted shrub model. The I-20 *Ultra* 4" and 6" pop-ups are also available with the optional stainless-steel riser sleeve, and all models may be ordered with a purple rubber cover for reclaimed water identification. The innovative FloStop® control is standard on all models.

6" Rotor Models...

Two models created especially for installations in tall grass

The Hunter I-20 *Ultra* offers a taller pop-up height: the 6" pop-up designed for maximum versatility in higher cut turf. A taller cutting height is becoming the accepted standard for maintaining turf because with the taller height comes the enhanced ability to weather drought conditions. With this capability, the turf can go for longer periods of time without irrigation.

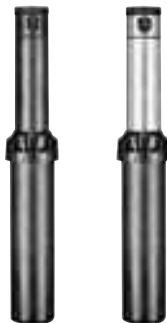

Some of the cooler season grasses, such as Tall Fescue, may grow as much as 2" between mowing periods. Maintaining this turf at a taller mow height (3" to 3½") would be a problem when using shorter rotors because within the mow period the grass may grow to 5½" high. This would be a full 1½" above the nozzle outlet, effectively blocking the water stream.

FloStop Control...

Flow shut-off for individual dry nozzle and arc changes

Do you want to change a nozzle while the system is running? Do you want to be able to stop the flow of water through a particular sprinkler while you adjust a neighboring head on the same zone? Is one area receiving too much water and you want to shut off just that one rotor? Only the I-20 *Ultra* with the innovative FloStop control allows you to temporarily turn off the flow of water through an individual head while the rest of the zone operates.

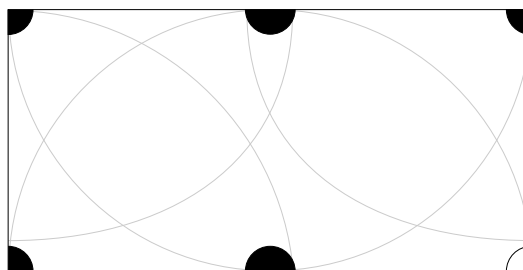
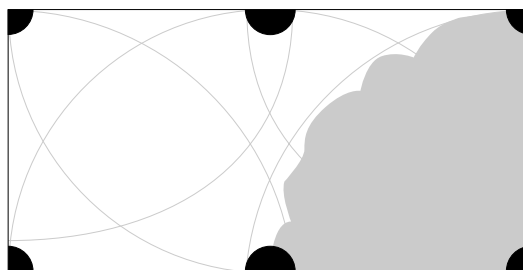

Eliminate Wet Spots with FloStop

Temporarily turn off a rotor to reduce excess moisture due to shade or soil composition.

I-20 Ultra Rotors

Sprinkler Adjustments

Without FloStop® water from nearby sprinkler heads can get you wet.

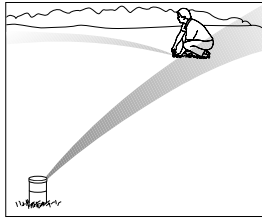

With FloStop you can temporarily turn off the flow of water from nearby heads.

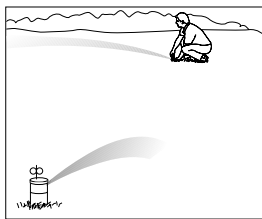

With FloStop you stay dry when adjusting a sprinkler positioned near a barrier such as a fence or hedge.

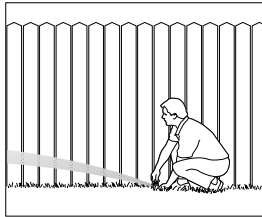

Superior Coverage – Across the Range...

8 standard and 4 low angle nozzles

With every sprinkler in the I-20 Ultra rotor group, twelve nozzles are included on one rack—FREE! 8 standard – (25' trajectory) and 4 low angle (13' trajectory) nozzles. Totally interchangeable and recyclable, these twelve nozzles provide maximum flexibility for any irrigation system application.



Only the I-20 Ultra provides excellent coverage close to the sprinkler as well as throughout its entire distance of throw. The exceptional performance of I-20 Ultra nozzles guarantees uniform results – with no wet or dry spots in all head-to-head spacing installations from 25' to 47' (7,6 to 14,3 m). Plus, with the built-in nozzle removal tab, the nozzles are readily interchanged and adjusted, allowing the installer to easily fine tune the system to meet field conditions. If wind, slopes or low

hanging tree branches are concerns, use the low angle nozzles.

If there is a need to water a smaller area, request the I-20 Ultra 18' or 25' nozzles from your distributor for precise coverage in those tough circumstances.

Short Distance Nozzles...

The coverage range of a spray with the benefits of a commercial-grade rotor

The I-20 Ultra Short Distance Nozzles (p/n 466100)

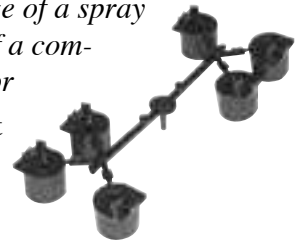

have been uniquely

crafted for turf areas needing a smaller radius. This “six pack” of nozzles includes three 18' (5,5 m) distance nozzles (at 50 PSI) (3.4 bars) with flow rates of 0.50, 1.0, 2.0 GPM (1,89; 3,79; 7,57 lpm) and three 25' (7,6 m) distance nozzles (at 50 PSI) (3.4 bars) with flow rates of 0.75, 1.5, 3.0 GPM (2,84; 5,68; 11,36 lpm). These nozzles will precisely irrigate the area you want without wasting water beyond your desired throw. This nozzle rack is available at your distributor as a separate part to the I-20 Ultra rotor.

High Flow Nozzles...

Higher precipitation rates are achieved when needed

For systems that need to deliver water at higher than normal flow rates, the I-20 Ultra High Flow Nozzles (p/n 444800)



are the answer. The nozzle tree includes two (#10, #13) standard angle nozzles and two (#6 LA, #8 LA) low angle nozzles with flows of 4.2 to 14.8 GPM (15,9 to 56,0 lpm) and radius' of 31' to 47' (9,4 to 14,3 m). This nozzle rack is available at your distributor as a separate part to the I-20 Ultra rotor.

PRODUCT FEATURES AND BENEFITS *(continued)*

Square Top Designed Nozzles...

Self aligning makes nozzle installation easy

The new square top design makes the nozzle easy to install or change because the nozzle aligns itself automatically. With perfect alignment every time, the nozzle set screw will always screw in easily.



Proven, Long-Life Water Lubricated Gear Drive...

The #1 reliable gear drive system

A rotor needs to rotate – every time! Choose the one that will ensure you with reliability and time proven optimum performance. First introduced over 20 years ago and still being continuously improved,



Hunter's water lubricated gear drive system is #1 in the industry. Since that original commitment to irrigation, Hunter Industries has been improving the best light commercial rotor in the business.

Robust Construction...

Stands up to heavy equipment and foot traffic

The extremely tough body cap with ribbed reinforcement provides exceptional strength, making



heavy equipment and foot traffic no problem for this commercial grade rotor. Because of this rugged construction, the I-20 *Ultra* is vandal resistant.

Advanced Wiper Seal...

The most reliable and time proven pressure activated riser seal

The I-20 *Ultra* includes a heavy-duty pressure activated riser seal that has been designed for long life under harsh, gritty conditions. A special chemical agent is incorporated into the rubber to keep microbial action from damaging the seal. The surface area of the seal, which is in contact with the riser shaft, is large enough to stop all flow-by, but small enough to keep debris from lodging between the seal and the riser shaft. The I-20 *Ultra* riser seal has the capability to be easily lowered on the riser shaft for cleaning, or replacement thus keeping the benefits of a no flow-by rotor.



5-Year Warranty...

A product that's sure to endure

Combine the continuously improved gear-drive system (backed by over two decades of proven reliability) and the *Ultra* sturdy construction of this commercial grade industry leading rotor, and you'll see why it's easy for Hunter to provide a full 5-year warranty on the I-20 *Ultra*.

Date Coding...

The easy way to identify exactly when your rotor was manufactured

All the I-20 *Ultra* Series rotors have the manufactured date code stamped on the side of the nozzle turret. The date code is stamped with a four digit code – the first two digits representing the year, the last two digits indicating the month (e.g., 03 08 stands for August 2003).

40° to 360° Adjustable Arc or Full Circle Versions...

For fastest, hassle-free adjustment, wet or dry, up or down

The I-20 *Ultra* Adjustable Arc Rotor is the all-in-one sprinkler because of its reversing full circle and part-circle operation in one unit. With its 40° to 360° Adjustable Arc, most odd shaped areas can be irrigated with a quick turn of the Hunter wrench. The I-20 *Ultra* can be

I-20 Ultra Rotors

adjusted up or down, wet or dry, for maximum convenience. Only one rotor is needed to cover those curving shrub beds and odd-angled hardscapes.

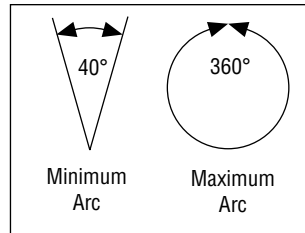

Optional Stainless Steel Riser... *Extra heavy-duty protection*

The optional stainless steel riser sleeve not only adds strength to the sprinkler, but also protects the riser and seal from excessive wear and tear. Abrasive sandy soils may score plastic risers and seals causing them to leak prematurely or cause riser “stick-ups”. Even when challenged by adverse soil conditions like these, the stainless steel riser helps to add years to the rotor’s life.



Commercial Grade Retract Spring... *Reliable retraction every time*

The I-20 Ultra extra heavy duty commercial grade retraction spring ensures positive pop-down. Whether it’s used in a commercial or residential application, rest assured this head will retract correctly every time.

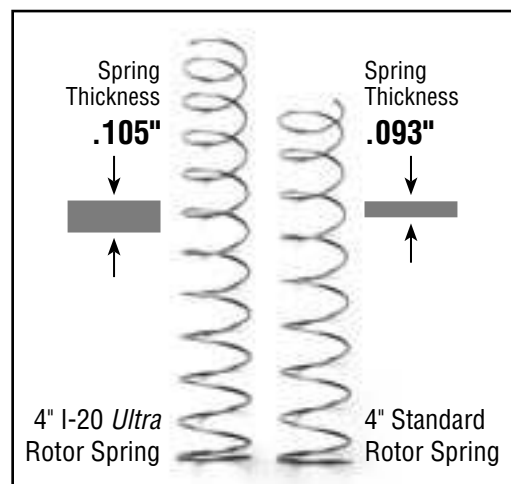

Standard Integral Rubber Cover... *Keeps dirt out, permanently installed*

An EXTRA THICK soft rubber cover and a small exposed surface area (1¾", 4 cm diameter) combine to make the I-20 Ultra ideal for play areas.

With its unique flexible membrane, the cover ensures that the adjustment sockets will always be covered, thus protecting the internal mechanism from dirt intrusion. It’s also simple to increase or decrease the arc settings using the adjustment socket symbols, while the nozzle locator arrow provides immediate recognition of direction of the nozzle stream.

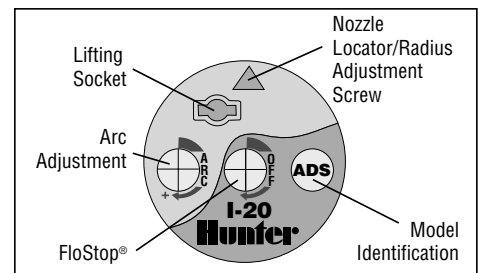

Factory Installed Nozzles...

Convenience for large projects

Hunter is always looking for ways to help the installer be more cost effective. The I-20 Ultra can be ordered with factory installed nozzles to reduce the amount of time needed to install sprinklers. This convenience on large projects translates to a lot of time potentially saved on the job.

Quick Check Arc/Fast Forward...

Quick verification of arc stop points

The I-20 Ultra allows the user to check the right and left arc stops without affecting the original settings. The ability to manually move the arc in a fast forward manner allows the installer to set the sprinkler arc more rapidly. While this “quick check” is most accurate with

PRODUCT FEATURES AND BENEFITS (continued)

water flowing, checking while dry will also give a very good idea of the arc settings. With the riser in the extended position, turn the top of the riser back and forth with just one's fingers. Where the arc stops will be very close to the same point as when the rotor is operating under water pressure.

Drain Check Valve for up to 10' Elevation Change...

Saves water, reduces liability

A drain check valve is a standard feature on all I-20 *Ultra* models. The check valve is designed to hold without leakage, the equivalent of 10' (3 m) of water pressure. Stopping low head drainage eliminates washouts and wasted water, and may also prevent accidents from occurring and pests from showing up. Also, due to water remaining in the pipes, installers may benefit from the reduction of potential "water hammer" surge damage.

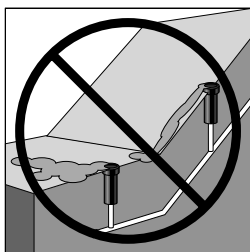

No wasteful low-head drainage

3-Spring Reversing Mechanism...

Reliability when it's needed

The three springs in the I-20 *Ultra* reversing mechanism create a very sharp, crisp reverse trip action generating precise control of the arc stops. Just about every adjustable rotor on the market has a 2-spring reversing mechanism that results in a somewhat soft, non-precise reversing trip, which tends to creep over time.

Heavy Duty Body Cap Threads...

Super coarse for super performance

Muddy soil? The heavy duty threads on the I-20 *Ultra* are designed to take it. Adverse soil



conditions won't interfere with the threading process with these super coarse threads. Need to service the

filter screen? Just a few quick turns and the riser is out with the I-20 *Ultra*.

"Jar Top" Convenience...

Simplifies servicing

If cleaning the screen becomes necessary, simply unscrew the cap — the internals will come out as one piece, not in multiple parts that end up getting lost or broken. And there are no special tools or training classes needed to take apart the I-20 *Ultra*.

Large Dirty Water Filter Screen...

Puts an end to clogging

If dirty water is in use, the large filter screen helps prevent clogging of the nozzle. The screen is easily serviced without removing the sprinkler body from the line.



Optional Purple Rubber Cover...

Identifies non-potable water

Don't leave the identification of your system's water source up to question.



The I-20 *Ultra* permanent rubber cover is also available in purple — denoting the use of reclaimed water.

Shrub Staking Kit...

Secure installation of shrub rotors on slopes or in shrub areas

The Hunter Shrub Staking Kit allows contractors to install the PGS and I-10 rotor quickly and easily on slopes and in shrub beds.



TECHNICAL INFORMATION

Nozzle Trajectory...

This rotor nozzle trajectory chart is designed to help determine how close a sprinkler can be placed to an object such as a fence or hedge without obstructing the spray pattern. All information shown is at optimum operating pressures.

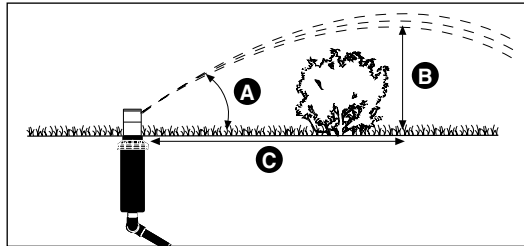

Hunter Nozzle Height and Trajectory Chart

Sprinkler Model	Nozzle No.	Pressure in PSI	Degrees of Trajectory	Max Height of Spray (ft.)	Distance from head (ft.) to Max. Height
I-20 Ultra	1.0	50	A 25	B 8'	C 23'
	1.5	50	25	8'	23'
	2.0	50	25	9'	26'
	3.0	50	25	10'	28'
	3.5	50	25	11'	30'
	4.0	50	25	11'	30'
	6.0	50	25	12'	32'
	8.0	50	25	25	13'
Low Angle I-20 Ultra	2.0LA	50	13	5'	22'
	2.5LA	50	13	4'	22'
	3.5LA	50	13	4'	22'
	4.5LA	50	13	5'	24'

Note: All performance data is derived from testing at 4" above finished grade.

MODELS

- I-10 – Shrub
- I-20 – 4" Pop-up (10 cm)
- I-20-6P – 6" Pop-up (15 cm)
- I-20-HP – 12" Pop-up (30 cm)

DIMENSIONS

- Overall height:
 - I-10 – 7¾" (20 cm)
 - I-20 – 7¾" (- cm)
 - I-20-6P – 9⅞" (25 cm)
 - I-20-HP – 17" (43 cm)
- ¾" female inlet NPT
- Exposed diameter: 1¾" (4 cm)

OPERATING SPECIFICATIONS

- Discharge rate: 0.36 to 14.8 gpm (0,08 to 3,7 m³/hr; 1,4 to 56,0 l/min)
- Radius: 17' to 47' (5,2 to 14,3 m)
- Pressure range: 30 to 70 psi (2,1 to 4,8 bars; 206 to 482 kPa)
- Precipitation rates: approximately 0.4" (10 mm) per hour at 50 psi (3,4 bars; 344 kPa) for spacings from 17' to 47' (5,2 to 14,3 m)
- Nozzle trajectory: standard – 25°/low-angle – 13°
- Drain check valve for up to 10' (3.0 m) elevation change

OPTIONS AVAILABLE

- Reclaimed water cover
- Stainless steel riser (I-20, I-20-6P)
- Factory installed nozzles

PRODUCT COMPARISONS

Features	Hunter I-20 Ultra	Toro Super 700	Toro Super 600	Toro V-1550	Rain Bird T-Bird (T-40)	Rain Bird R-50
Radius	17' – 47'	21' – 52'	35' – 50'	19' – 55'	26' – 50'	26' – 50'
Radius (m)	5,1 – 14,3	6,4 – 15,8	10,7 – 15,2	5,8 – 16,8	7,9 – 15,2	7,9 – 15,2
All standard & low angle nozzles included in box	✓			✓		
Pull-up socket for easy servicing	✓					
Up, down, wet or dry arc adjustable from the top	✓			✓		
Quick check arc	✓	✓	✓		✓	✓
Easy to read adjustment symbols on top	✓					
FloStop® Control	✓					
Exposed diameter	1¾" (4 cm)	3" (8 cm)	3" (8 cm)	2⅝" (7 cm)	2" (5 cm)	2" (5 cm)
Permanent rubber cover	✓			center only		
Proven, reliable 3 spring reversing mech	✓					
Optional stainless steel riser	✓	✓				
Standard extra heavy duty retract spring	✓			✓		
Check height for standard installed drain check valve	10' (3 m)	N/A	N/A	10' (3 m)	N/A	N/A
Warranty:	5 year exchange	2 year limited	2 year limited	3 year limited	5 year trade	5 year trade

Features	Hunter I-20 Ultra	Rain Bird 5000	Nelson Pro 6000	Irritrol XL	Weathermatic Turbo 3	K-Rain K-2
Radius	17' – 47'	23' – 50'	26' – 51'	30' – 48'	28' – 53'	22' – 55'
Radius (m)	5,5 – 15,5	7,0 – 15,2	7,9 – 15,5	10,0 – 14,6	8,5 – 16,1	6,7 – 16,8
All standard & low angle nozzles included in box	✓					
Pull-up socket for easy servicing	✓	✓		✓	✓	✓
Up, down, wet or dry arc adjustable from the top	✓	✓				✓
Quick check arc	✓	✓		✓	✓	✓
Easy to read adjustment symbols on top	✓	✓		✓		✓
FloStop® Control	✓					
Exposed diameter	1¾" (4 cm)	1¾" (4 cm)	1⅞" (5 cm)	1⅞" (5 cm)	2" (5 cm)	2" (5 cm)
Permanent rubber cover	✓	✓	✓	✓	✓	✓
Proven, reliable 3 spring reversing mech	✓					✓
Optional stainless steel riser	✓		✓		✓	✓
Standard extra heavy duty retract spring	✓				✓	
Check height for standard installed drain check valve	10' (3 m)	N/A	N/A	N/A	10' (3 m)	N/A
Warranty:	5 year exchange	5 year trade	5 year limited	5 year limited	5 year exchange	5 year limited

Rain Bird® is a registered trademark of Rain Bird Sprinkler Manufacturing Corporation

Nelson® is a registered trademark of L. R. Nelson Corporation

Weathermatic® is a registered trademark of Telsco Industries

Toro® is a registered trademark of The Toro Company

Irritrol® is a registered trademark of the Irritrol® Systems

K-Rain® is a registered trademark of the K-Rain Company

I-20 Ultra Rotors

NOZZLE REPLACEMENT GUIDE

I-20 Ultra Gear Driven Rotor for Spacings of 25 to 47 feet (5,1 to 14,3 meters)					
To Replace		Use Hunter Nozzle	To Replace		Use Hunter Nozzle
RAIN BIRD			TORO		
Mini-Paw 15103	07 (Black)	3.0	Stream Rotor	3404-XX-02	1.0
	09 (Green)	3.5		3408-XX-02	1.5
Maxi-Paw 2045	06 (Red)	2.0		3416-XX-02	3.5
	07 (Black)	3.0		3404-XX-03	1.5
	08 (Blue)	4.0		3408-XX-03	3.0
	10 (Yellow)	6.0		3416-XX-03	6.0
R-50	12 (Beige)	8.0	XP 300 Series	XP-300-090-07	1.5
	1.5 (Black)	2.0		180-07	3.0
	2.0 (Brown)	3.0		360-07	6.0
	3.0 (Gray)	4.0		090-09	2.0
	4.0 (Yellow)	6.0		180-09	4.0
T-Bird T-22	6.0 (Green)	8.0		360-09	8.0
	1.0 (Red)	.75 (25')		090-10	2.0
	2.0 (Brown)	1.5 (25')		180-10	4.0
T-Bird T-30	4.0 (Yellow)	3.0 (25')		360-10	8.0
	1.0 (Red)	1.0		320 Rain Pro	324-XX-05
	1.3 (Black)	1.5	328-XX-05		3.5
	2.0 (Brown)	2.0	328-XX-06		8.0
	2.5 (Gray)	3.0	336-XX-05		3.0
4.0 (Yellow)	3.5	336-XX-06	6.0		
5.0 (Green)	6.0	Super 600	1.3		1.5
T-Bird T-40	1.0 (Red)		1.0	2.5	3.5
	1.5 (Black)		2.0	5.0	8.0
	2.0 (Brown)	3.5	Super 700	1.5	1.5
	3.0 (Gray)	4.0		2.0	2.0
	4.0 (Yellow)	6.0		3.0	3.5
6.0 (Green)	8.0	4.5		4.0	
6.0	8.0	6.0		6.0	
5000	1.0	1.0	7.5	8.0	
	1.5	1.5	9.0	8.0	
	2.0	2.0			
	3.0	3.5			
	4.0	4.0			
	6.0	6.0			
15111	10 (5/32" nozzle)	4.0			
21A, 27A	10 (5/32" nozzle)	4.0			
25	10 (5/32" nozzle)	4.0			
31A, 37A	14 (7/32" nozzle)	8.0			
35	12 (3/16" nozzle)	8.0			

To Replace		Use Hunter Nozzle
NELSON		
Mini Rotor	6702 (Green)	2.0
	6703 (Red)	3.5
	6704 (Black)	4.0
Pro 6000	4	1.0
	5	1.5
	6	2.0
	7	3.0
	8	4.0
	9	6.0
Pro 6500	10	8.0
	61	3.0
Pro 6500	62	6.0
	63	8.0
	63	8.0
WEATHERMATIC		
G40P & G40FS		3.5
G50P		6.0
G60P & G40F		8.0
TJ2/TJ3	4	1.5
	5	2.5
	6	3.0
	7	3.5
	8	4.0
	9	6.0
SINGLE NOZZLE all impact mfrs.	10	8.0
	7/64"	2.0
	1/8"	3.5
	9/64"	4.0
	5/32"	6.0
11/64"	6.0	
3/16"	8.0	

SPECIFICATION GUIDE

EXAMPLE: **I-20 - ADS - 3.0**

MODEL	FEATURES	OPTIONS
I-10 = Shrub	ADV, 36V, ARV, 3RV	XX = Complete Set of Nozzles
I-20 = 4" Pop-up	ADV, 36V, ADS, 36S, ARV, 3RV, ARS, 3RS, ADJ, 360	1.0 - 8.0 = Factory-Installed Standard Nozzles
I-20-6P = 6" Pop-up	ADV, 36V, ADS, 36S, ARV, 3RV, ARS, 3RS	2.0 LA - 4.5 LA = Factory-Installed Low Angle Nozzles
I-20-HP = 12" Pop-up	ADV, 36V, ARV, 3RV	

KEY TO FEATURES:

ADJ = Adjustable with no Check Valve	36S = Full-Circle with Check Valve and Stainless Steel Riser
360 = Full-Circle with no Check Valve	ARV = Adjustable, Reclaimed Water, with Check Valve
ADV = Adjustable with Check Valve	3RV = Full-Circle, Reclaimed Water, with Check Valve
36V = Full-Circle with Check Valve	ARS = Adjustable, Reclaimed Water and Stainless Steel Riser
ADS = Adjustable with Check Valve and Stainless Steel Riser	3RS = Full-Circle, Reclaimed Water and Stainless Steel Riser

PRODUCT PERFORMANCE

I-10/I-20 Ultra Standard Nozzle Performance Data					
Nozzle	Pressure PSI	Radius ft.	Flow GPM	Precip in/hr	
				■	▲
1.0	30	30'	0.9	0.19	0.22
	40	31'	1.0	0.20	0.23
	50	31'	1.2	0.24	0.28
	60	32'	1.3	0.24	0.28
1.5	30	32'	1.2	0.23	0.26
	40	33'	1.4	0.25	0.29
	50	34'	1.6	0.27	0.31
	60	34'	1.8	0.30	0.35
2.0	30	34'	1.6	0.27	0.31
	40	36'	1.8	0.27	0.31
	50	38'	2.0	0.27	0.31
	60	38'	2.2	0.29	0.34
3.0	30	36'	2.0	0.30	0.34
	40	38'	2.4	0.32	0.37
	50	40'	2.7	0.32	0.38
	60	40'	2.9	0.35	0.40
3.5	30	36'	2.6	0.39	0.45
	40	40'	3.0	0.36	0.42
	50	42'	3.4	0.37	0.43
	60	42'	3.7	0.40	0.47
4.0	30	37'	3.2	0.45	0.52
	40	40'	3.7	0.45	0.51
	50	43'	4.2	0.44	0.50
	60	44'	4.6	0.46	0.53
6.0	30	35'	4.2	0.66	0.76
	40	40'	4.9	0.59	0.68
	50	43'	5.5	0.57	0.66
	60	44'	6.0	0.60	0.69
8.0	40	41'	6.0	0.69	0.79
	50	44'	6.8	0.68	0.78
	60	45'	7.6	0.72	0.83
	70	47'	8.2	0.71	0.83

I-10/I-20 Ultra 18' Short Radius Nozzle Performance Data					
Nozzle	Pressure PSI	Radius ft.	Flow GPM	Precip in/hr	
				■	▲
.50 SR	30	17'	0.36	0.24	0.28
	40	17'	0.43	0.29	0.33
	50	18'	0.50	0.30	0.34
	60	19'	0.57	0.30	0.35
1.0 SR	30	17'	0.78	0.52	0.60
	40	17'	0.90	0.60	0.69
	50	18'	1.0	0.59	0.69
	60	19'	1.1	0.59	0.68
2.0 SR	30	17'	1.4	0.93	1.08
	40	17'	1.7	1.13	1.31
	50	18'	2.0	1.19	1.37
	60	19'	2.2	1.17	1.35

I-10/I-20 Ultra 25' Short Radius Nozzle Performance Data					
Nozzle	Pressure PSI	Radius ft.	Flow GPM	Precip in/hr	
				■	▲
.75 SR	30	23'	0.58	0.21	0.24
	40	24'	0.68	0.23	0.26
	50	25'	0.75	0.23	0.27
	60	26'	0.83	0.24	0.27
1.5 SR	30	23'	1.1	0.40	0.46
	40	24'	1.3	0.43	0.50
	50	25'	1.5	0.46	0.53
	60	26'	1.6	0.46	0.53
3.0 SR	30	23'	2.5	0.91	1.05
	40	24'	2.7	0.90	1.04
	50	25'	3.0	0.92	1.07
	60	26'	3.1	0.88	1.02

I-10/I-20 Ultra Low Angle Nozzle Performance Data					
Nozzle	Pressure PSI	Radius ft.	Flow GPM	Precip in/hr	
				■	▲
2.0 LA	30	25'	1.6	0.49	0.57
	40	27'	1.9	0.50	0.58
	50	28'	2.1	0.52	0.60
	60	30'	2.3	0.49	0.57
2.5 LA	30	27'	2.1	0.55	0.64
	40	30'	2.5	0.53	0.62
	50	33'	2.8	0.49	0.57
	60	35'	3.0	0.47	0.54
3.5 LA	30	29'	2.8	0.64	0.74
	40	32'	3.1	0.58	0.67
	50	35'	3.5	0.55	0.64
	60	37'	3.8	0.53	0.62
4.5 LA	30	31'	3.4	0.68	0.79
	40	34'	3.9	0.65	0.75
	50	37'	4.4	0.62	0.71
	60	38'	4.7	0.63	0.72

I-10/I-20 Ultra High Flow Standard Nozzle Performance Data					
Nozzle	Pressure PSI	Radius ft.	Flow GPM	Precip in/hr	
				■	▲
10	40	42'	8.4	0.92	1.06
	50	43'	9.5	0.99	1.14
	60	45'	10.5	1.00	1.15
	70	47'	11.4	0.99	1.15
13	40	43'	10.9	1.13	1.31
	50	44'	12.3	1.22	1.41
	60	45'	13.6	1.29	1.49
	70	47'	14.8	1.29	1.49

I-10/I-20 Ultra High Flow Low Angle Nozzle Performance Data					
Nozzle	Pressure PSI	Radius ft.	Flow GPM	Precip in/hr	
				■	▲
6.0 LA	30	31'	4.2	0.84	0.97
	40	35'	5.0	0.79	0.91
	50	37'	5.8	0.82	0.94
	60	39'	6.3	0.80	0.92
8.0 LA	40	37'	6.7	0.94	1.09
	50	39'	7.7	0.97	1.13
	60	41'	8.5	0.97	1.12
	70	41'	9.2	1.05	1.22

Note: All precipitation rates calculated for 180 degree operation.
For the precipitation rate for a 360 degree sprinkler, divide by 2.

I-20 Ultra Rotors

I-10/I-20 Ultra Standard Nozzle Performance Data – Metric

Nozzle	Pressure		Radius m	Flow		Precip mm/hr	
	Bars	kPa		m ³ /hr	l/min	■	▲
1.0	2.1	206	9.1	0.20	3.4	5	6
	2.8	275	9.4	0.23	3.8	5	6
	3.4	344	9.4	0.27	4.5	6	7
	4.1	413	9.8	0.30	4.9	6	7
1.5	2.1	206	9.8	0.27	4.5	6	7
	2.8	275	10.1	0.32	5.3	6	7
	3.4	344	10.4	0.36	6.1	7	8
	4.1	413	10.4	0.41	6.8	8	9
2.0	2.1	206	10.4	0.36	6.1	7	8
	2.8	275	11.0	0.41	6.8	7	8
	3.4	344	11.6	0.45	7.6	7	8
	4.1	413	11.6	0.50	8.3	7	9
3.0	2.1	206	11.0	0.45	7.6	8	9
	2.8	275	11.6	0.55	9.1	8	9
	3.4	344	12.2	0.61	10.2	8	10
	4.1	413	12.2	0.66	11.0	9	10
3.5	2.1	206	11.0	0.59	9.8	10	11
	2.8	275	12.2	0.68	11.4	9	11
	3.4	344	12.8	0.77	12.9	9	11
	4.1	413	12.8	0.84	14.0	10	12
4.0	2.1	206	11.3	0.73	12.1	11	13
	2.8	275	12.2	0.84	14.0	11	13
	3.4	344	13.1	0.95	15.9	11	13
	4.1	413	13.4	1.04	17.4	12	13
6.0	2.1	206	10.7	0.95	15.9	17	19
	2.8	275	12.2	1.11	18.5	15	17
	3.4	344	13.1	1.25	20.8	15	17
	4.1	413	13.4	1.36	22.7	15	17
8.0	2.8	275	12.5	1.36	22.7	17	20
	3.4	344	13.4	1.54	25.7	17	20
	4.1	413	13.7	1.73	28.8	18	21
	4.8	482	14.3	1.86	31.0	18	21

I-10/I-20 Ultra 5.5 m Short Range Nozzle Performance Data – Metric

Nozzle	Pressure		Radius m	Flow		Precip mm/hr	
	Bars	kPa		m ³ /hr	l/min	■	▲
.50 SR	2.1	206	5.2	0.08	1.4	6	7
	2.8	275	5.2	0.10	1.6	7	8
	3.4	344	5.5	0.11	1.9	8	9
	4.1	413	5.8	0.13	2.2	8	9
1.0 SR	2.1	206	5.2	0.18	3.0	13	15
	2.8	275	5.2	0.20	3.4	15	18
	3.4	344	5.5	0.23	3.8	15	17
	4.1	413	5.8	0.25	4.2	15	17
2.0 SR	2.1	206	5.2	0.32	5.3	24	27
	2.8	275	5.2	0.39	6.4	29	33
	3.4	344	5.5	0.45	7.6	30	35
	4.1	413	5.8	0.50	8.3	30	34

I-10/I-20 Ultra 7.6 m Short Range Nozzle Performance Data – Metric

Nozzle	Pressure		Radius m	Flow		Precip mm/hr	
	Bars	kPa		m ³ /hr	l/min	■	▲
.75 SR	2.1	206	7.0	0.13	2.2	5	6
	2.8	275	7.3	0.15	2.6	6	7
	3.4	344	7.6	0.17	2.8	6	7
	4.1	413	7.9	0.19	3.1	6	7
1.5 SR	2.1	206	7.0	0.25	4.2	10	12
	2.8	275	7.3	0.30	4.9	11	13
	3.4	344	7.6	0.34	5.7	12	14
	4.1	413	7.9	0.36	6.1	12	13
3.0 SR	2.1	206	7.0	0.57	9.5	23	27
	2.8	275	7.3	0.61	10.2	23	26
	3.4	344	7.6	0.68	11.4	23	27
	4.1	413	7.9	0.70	11.7	22	26

I-10/I-20 Ultra Low Angle Nozzle Performance Data – Metric

Nozzle	Pressure		Radius m	Flow		Precip mm/hr	
	Bars	kPa		m ³ /hr	l/min	■	▲
2.0 LA	2.1	206	7.6	0.36	6.1	13	14
	2.8	275	8.2	0.43	7.2	13	15
	3.4	344	8.5	0.48	7.9	13	15
	4.1	413	9.1	0.52	8.7	12	14
2.5 LA	2.1	206	8.2	0.48	7.9	14	16
	2.8	275	9.1	0.57	9.5	14	16
	3.4	344	10.1	0.64	10.6	13	15
	4.1	413	10.7	0.68	11.4	12	14
3.5 LA	2.1	206	8.8	0.64	10.6	16	19
	2.8	275	9.8	0.70	11.7	15	17
	3.4	344	10.7	0.79	13.2	14	16
	4.1	413	11.3	0.86	14.4	14	16
4.5 LA	2.1	206	9.4	0.77	12.9	17	20
	2.8	275	10.4	0.89	14.8	16	19
	3.4	344	11.3	1.00	16.7	16	18
	4.1	413	11.6	1.07	17.8	16	18

I-10/I-20 Ultra High Flow Standard Nozzle Performance Data – Metric

Nozzle	Pressure		Radius m	Flow		Precip mm/hr	
	Bars	kPa		m ³ /hr	l/min	■	▲
10	2.8	275	12.8	1.91	31.8	23	27
	3.4	344	13.1	2.16	36.0	25	29
	4.1	413	13.7	2.38	39.7	25	29
	4.8	482	14.3	2.59	43.1	25	29
13	2.8	275	13.1	2.48	41.3	29	33
	3.4	344	13.4	2.79	46.6	31	36
	4.1	413	13.7	3.09	51.5	33	38
	4.8	482	14.3	3.36	56.0	33	38

I-10/I-20 Ultra High Flow Low Angle Nozzle Performance Data – Metric

Nozzle	Pressure		Radius m	Flow		Precip mm/hr	
	Bars	kPa		m ³ /hr	l/min	■	▲
6.0 LA	2.1	206	9.4	0.95	15.9	21	25
	2.8	275	10.7	1.14	18.9	20	23
	3.4	344	11.3	1.32	22.0	21	24
	4.1	413	11.9	1.43	23.8	20	23
8.0 LA	2.8	275	11.3	1.52	25.4	24	28
	3.4	344	11.9	1.75	29.1	25	29
	4.1	413	12.5	1.93	32.2	25	29
	4.8	482	12.5	2.09	34.8	27	31

Note: All precipitation rates calculated for 180 degree operation.
For the precipitation rate for a 360 degree sprinkler, divide by 2.

INSTALLATION DETAILS

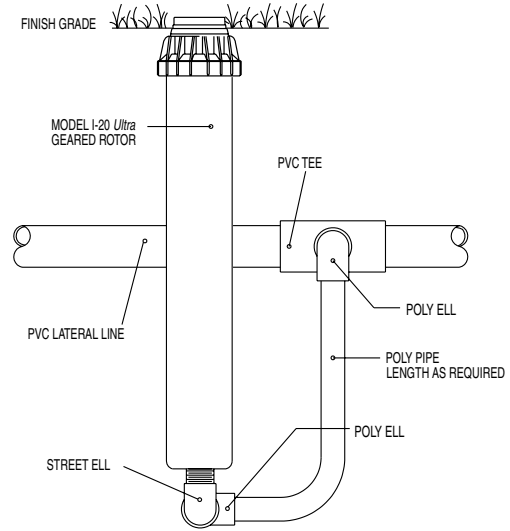
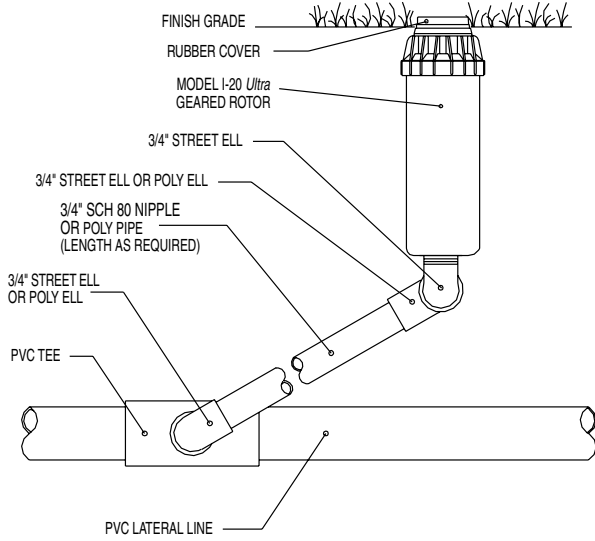

Hunter® I-20 Ultra

Hunter® I-20-HP

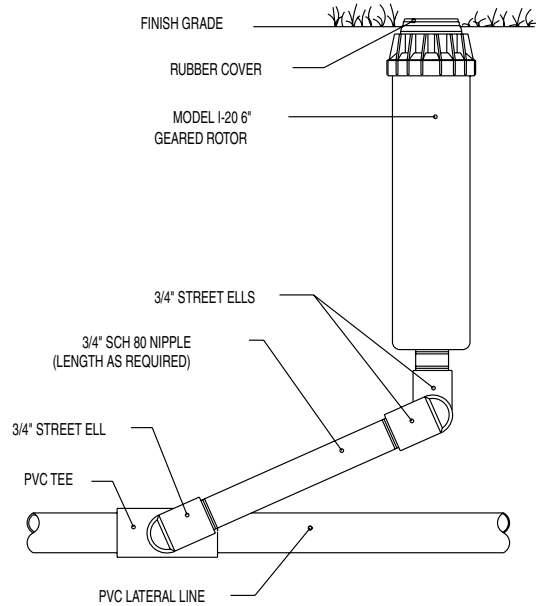
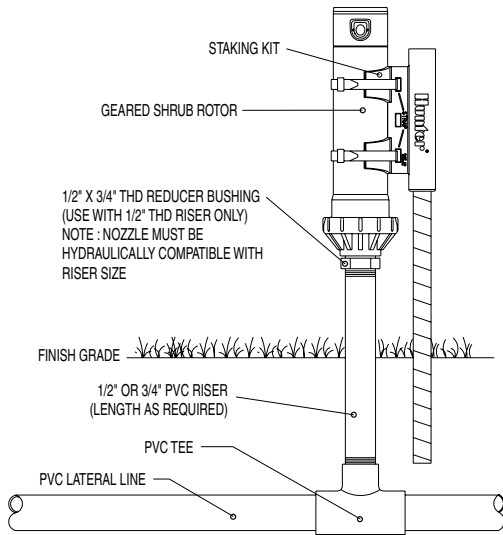

Hunter® I-10 Ultra Shrub

Hunter® I-20-6P

I-20 Ultra Rotors

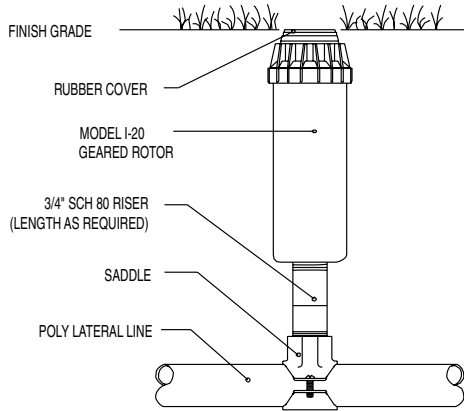

Hunter® I-20 ULTRA

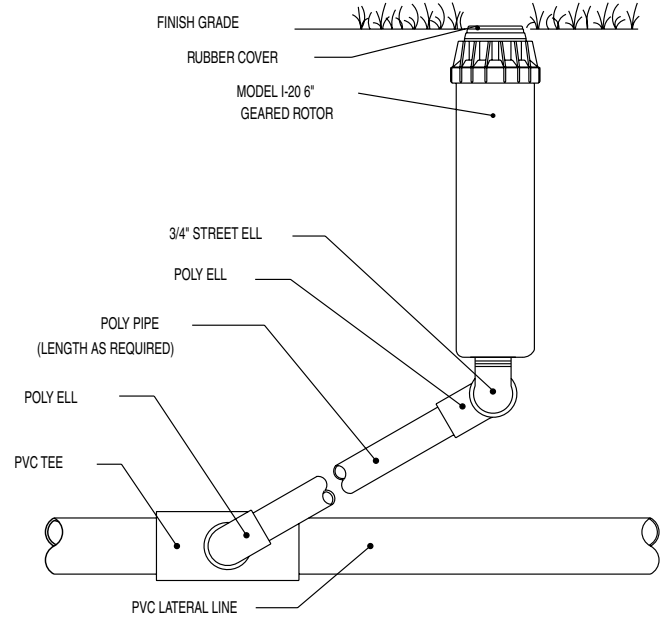

Hunter® I-20-6P

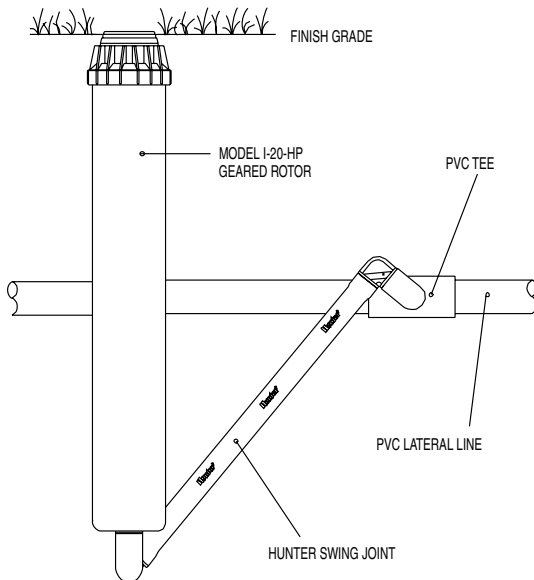

Hunter® I-20-HP

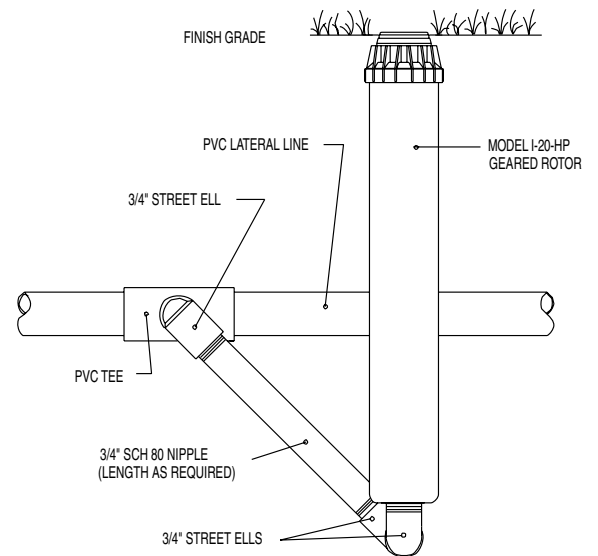

Hunter® I-20-HP

SHRUB STAKING INSTALLATION

Shrub Staking Kit...

Secure installation of shrub rotors on slopes and shrub areas

The new Hunter Shrub Staking Kit allows contractors to install I-10 *Ultra* with ease and security to assure complete sprinkler stability and vandal resistance. The kit is used with a ½" (1.5 cm) rebar stake and is then attached to the sprinkler. The staking kit comes with one plastic tie strap that is 14" (34 cm) long. Additional straps can be purchased if needed. One strap is the preferred method, but the staking kit will accept up to three straps. If the installer prefers using a gear clamp instead of the plastic strap, the slots on the staking kit are wide enough to accept the clamp.

The Shrub Staking Kit reduces the potential for injury by providing a protective covering over the top of the rebar stake.

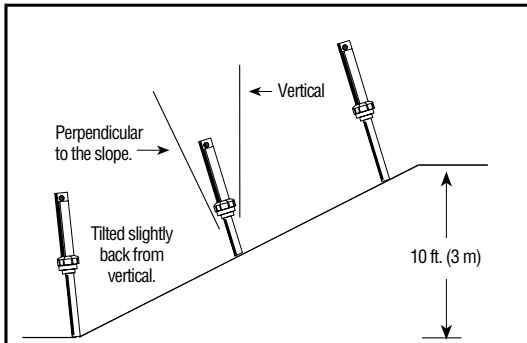

Typical slope installation using I-10 Ultra shrub sprinklers with standard check valve holding back water pressure from 10' of elevation change.

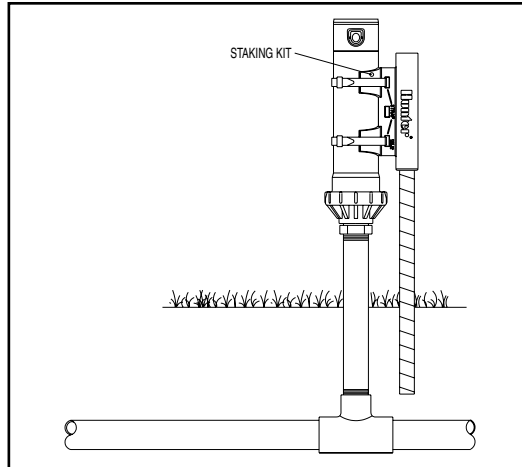

Easy to use:

1. Install the sprinkler on a riser.
2. Drive a ½" (1.5 cm) rebar stake into the ground, being careful not to hit the sprinkler piping system.
3. Insert the staking kit onto the rebar stake and up against the sprinkler.
4. Insert the plastic strap through the staking kit and around the sprinkler.
5. Pull the end of the strap so it is tight around the sprinkler.
6. Clip off any excess strap that is remaining.

Easy to order:

Hunter p/n 46-3551

INSTALLATION AND ADJUSTMENT GUIDE

The I-20 *Ultra* pop-up sprinkler should be installed at finished grade as shown in the illustration (Fig. 1).

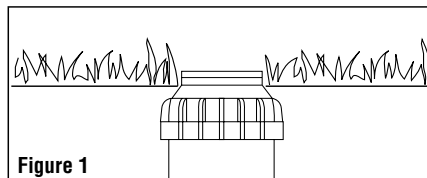

Arc Adjustments

Adjustable heads are preset to approximately 180 degrees. Sprinklers may be adjusted with water on or off. It is recommended that initial adjustments be made before installation.

1. Using the palm of your hand, rotate the nozzle turret counterclockwise to the left stop to complete any interrupted rotation cycle (Fig. 2).

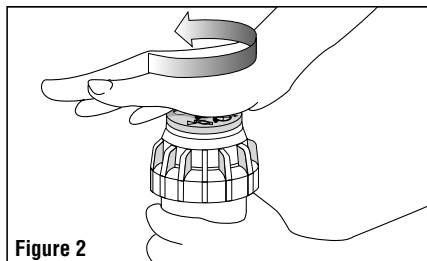

2. Rotate the nozzle turret clockwise to the right stop. The nozzle turret must be held in this position for all arc adjustments. The right stop does not change.

3. You can adjust to any arc between 40 and 360 degrees.

4. The wrench will stop turning, or there will be a ratcheting noise when the minimum arc of 40 degrees or the maximum arc of 360 degrees (full circle) has been reached (Fig. 3).

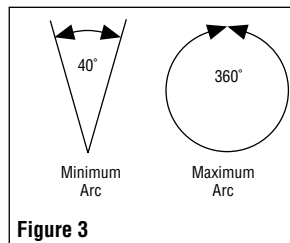

5. Insert the plastic key end of the Hunter wrench into the adjustment socket (Fig. 4).

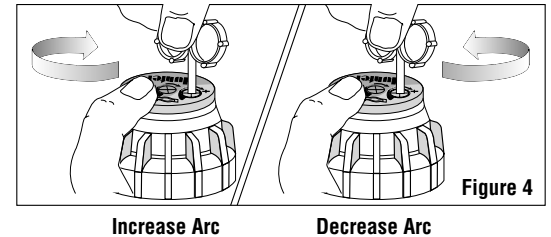

To Increase Arc:

While holding the nozzle turret at the right stop, turn the wrench **clockwise**.

To Decrease Arc:

While holding the nozzle turret at the right stop, turn the wrench counter-clockwise.

Each full 360 degree turn of the wrench decreases the arc 90 degrees.

Note: It is not necessary to disassemble the sprinkler to make arc adjustments.

Radius / Distance of Throw

1. Insert the hex end of the Hunter wrench into the nozzle/range-adjustment screw (Fig 5).
2. Turn the screw clockwise (into the stream of water) to decrease the radius, or counterclockwise to increase the radius.

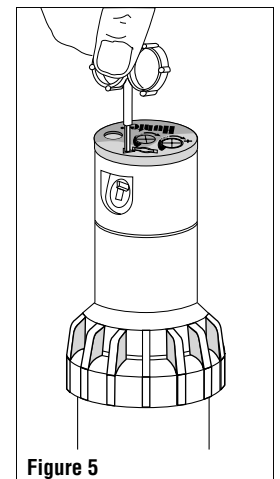

Note: Reducing the radius more than 25% will distort the even distribution of water. Turning the adjustment screw clockwise more than five full turns may result in a lost radius adjustment screw.

Precipitation Rate Adjustment

If you have excessively wet or dry areas, you can change the nozzle in the sprinkler to increase or decrease the precipitation rate. For dry areas, install a larger nozzle. For wet areas, install a smaller nozzle.

INSTALLATION AND ADJUSTMENT GUIDE

(continued)

Nozzle Installation

1. Insert the plastic key end of the Hunter wrench into the lifting socket of the sprinkler and turn 90 degrees. Pull the riser up to gain access the nozzle socket (Fig 6).

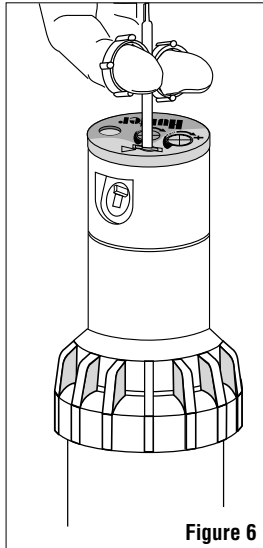

2. Using the hex key end of the Hunter wrench, turn the nozzle range-adjustment screw counterclockwise to be sure it is not blocking the nozzle socket opening. If a nozzle is already installed, it can be removed by backing out the adjustment screw and turning on the water, or by pulling outward on the nozzle removal post with a pair of needle-nosed pliers.
3. Slip the desired nozzle into the socket (Fig. 7). Note that the socket is angled up 25 degrees. Then tighten the nozzle range screw. The triangle on the rubber cover will always indicate the direction of the nozzle when the sprinkler is retracted.

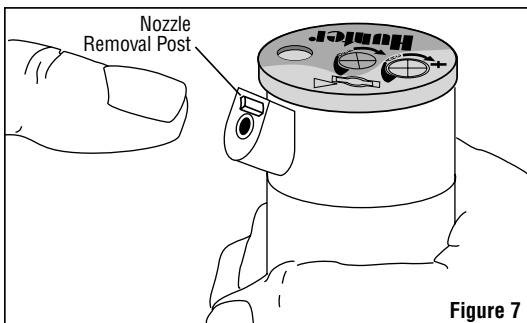

Aligning the Right (Fixed) Side of the Arc

There are two ways to align the right stop.

1. Turn the whole sprinkler body assembly and the fitting below it, left or right to the desired position.

2. Unscrew the body cap counter-clockwise and remove the internal assembly from the body (Fig. 8). Once removed, rotate the nozzle turret to the right stop, screw the internal assembly back into the body with the nozzle aligned to the right side of the area you want irrigated. At this point you have realigned the right arc stop, you can now adjust the left arc to an appropriate setting.

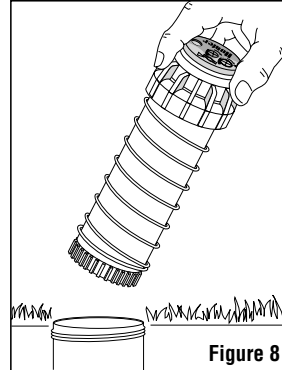

Note: It is not necessary to dig up and remove the whole sprinkler to realign the right arc.

Adjusting the Flow

Insert the plastic key end of the Hunter wrench into the FloStop® flow adjustment socket (Fig. 9). Turn wrench clockwise to shut off the flow. Turn the wrench counterclockwise to turn the flow back on.

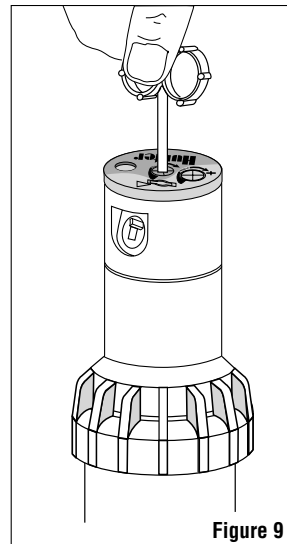

I-10 REPLACEMENT PARTS

Item	Description	Catalog No.	
①	Standard and Low Angle Nozzle Set (12)	356605	
②	High Flow Standard & Low Angle Nozzle Set (4)	444800	
③	Short Radius Nozzles	466100	
④	Universal Screw	120300	
⑤	Rubber Cover	ADV (Black)	307900
		36V (Black)	308400
		ARV (Purple)	297900
		3RV (Purple)	298000
⑥	Riser Assembly	ADV, ARV	361400
		36V, 3RV	364700
⑦	Check Valve Spring	235000	
⑧	Filter Screen/Check Valve Assembly (<i>Black</i>)	142300	
⑨	Check Valve Seal	101400	
⑩	Retainer Clip	204900	
⑪	Shrub Head Base for Check Valve Use	234900	

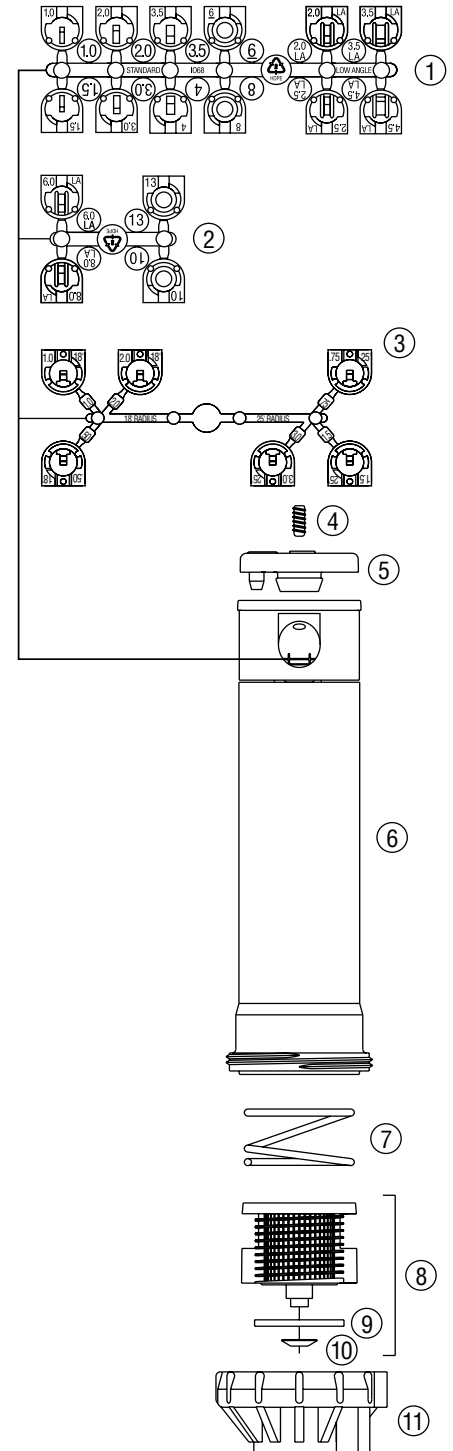

I-20 & I-20-6P REPLACEMENT PARTS

Item	Description	Catalog No.	
①	Standard and Low Angle Nozzle Set (12)	356605	
②	High Flow Standard & Low Angle Nozzle Set (4)	444800	
③	Short Radius Nozzles	466100	
④	Universal Screw	120300	
⑤	Rubber Cover	ADV (Black)	352400
		36V (Black)	352405
		ADS (Black)	352420
		36S (Black)	352425
		ADJ (Black)	352460
		360 (Black)	352465
		ADJ-SS (Black)	352470
		360-SS (Black)	352475
		ARV (Purple)	352410
		3RV (Purple)	352415
		ARS (Purple)	352430
		3RS (Purple)	352435
⑥	4" Riser Assembly	ADV, ARV	361300
		36V, 3RV	362800
⑦	Stainless Steel 4" Riser Assembly	ADS, ARS	361200
		36S, 3RS	362900
⑧	6" Riser Assembly	ADV, ARV	434300
		36V, 3RV	472600
⑨	Stainless Steel 6" Riser Assembly	ADS, ARS	434400
		36S, 3RS	472700
⑩	Filter Screen/Check Valve Assembly (Black)	142300	
⑪	Check Valve Seal	101400	
⑫	Retainer Clip	204900	
⑬	Body Cap	356000	
⑭	Seal Support	102300	
⑮	Riser Seal	252500	
⑯	Spring Seat	227800	
⑰	Retraction Spring	4"	150600
		6"	460300
⑱	Pop-Up Body	4"	229200
		6"	434700

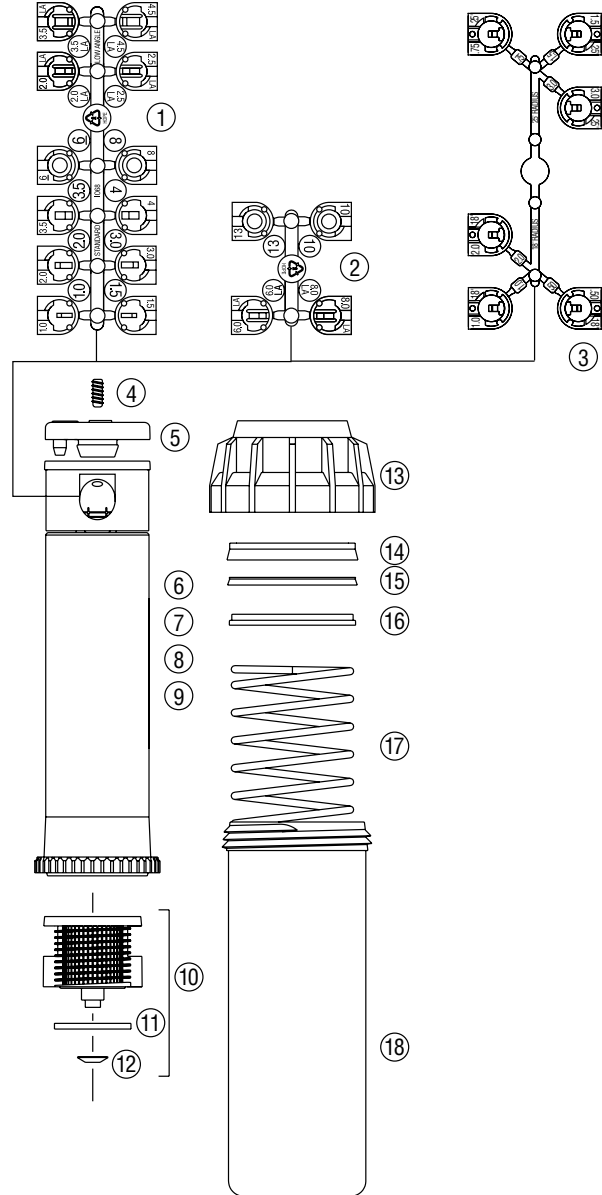

I-20 Ultra Rotors

I-20-HP REPLACEMENT PARTS

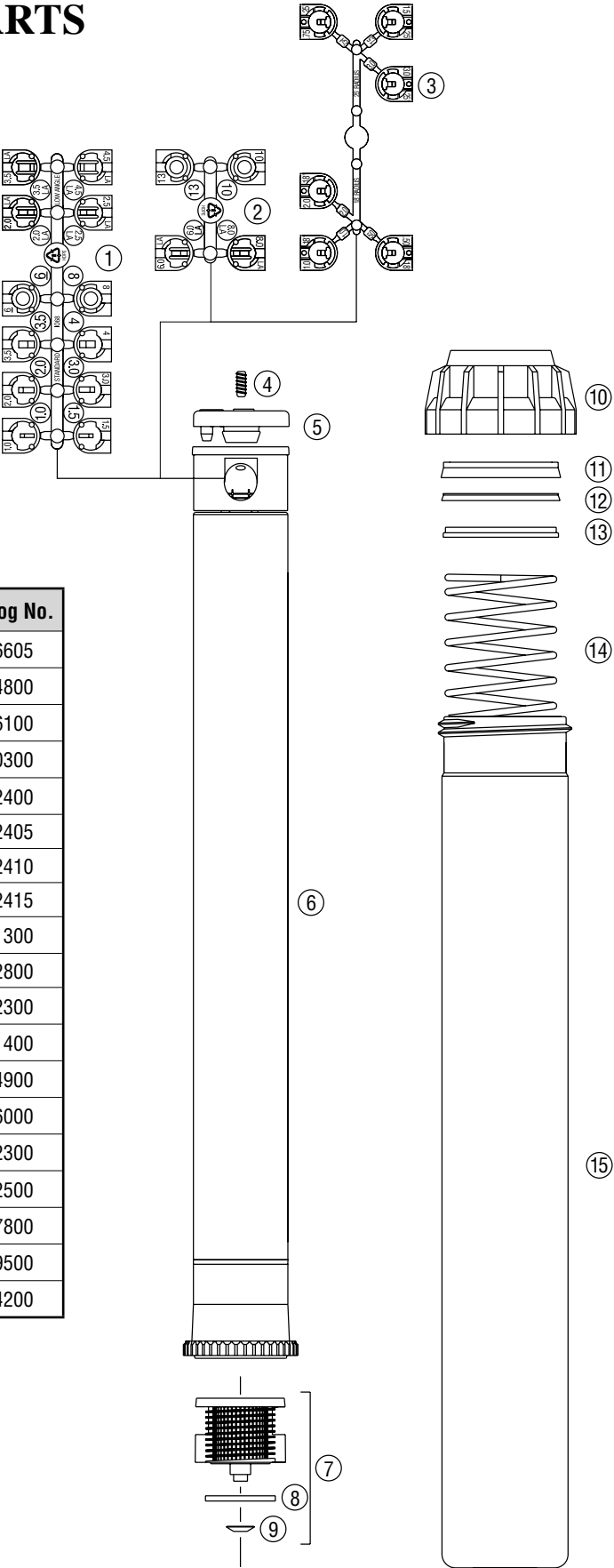

Item	Description	Catalog No.	
①	Standard and Low Angle Nozzle Set (12)	356605	
②	High Flow Standard & Low Angle Nozzle Set (4)	444800	
③	Short Radius Nozzles	466100	
④	Universal Screw	120300	
⑤	Rubber Cover	ADV (Black)	352400
		36V (Black)	352405
		ARV (Purple)	352410
		3RV (Purple)	352415
⑥	Riser Assembly	ADV, ARV	361300
		36V, 3RV	362800
		Filter Screen/Check Valve Assembly (Black)	142300
⑧	Check Valve Seal	101400	
⑨	Retainer Clip	204900	
⑩	Body Cap	356000	
⑪	Seal Support	102300	
⑫	Riser Seal	252500	
⑬	Spring Seat	227800	
⑭	Retraction Spring	179500	
⑮	Pop-Up Body	404200	

PRECIPITATION RATE

Two formulas are shown below, the first is most useful when comparing precipitation rates between different types of sprinklers or calculating precipitation rates on areas with a single type of sprinkler and uniform head and row spacing. The second method is better suited to areas where sprinkler head flows or spacing varies. Metric versions are shown in parenthesis.

Precipitation Rate - Method #1 - Individual Head Method

$$Pr = \frac{34650 \times \text{GPM (for any arc)}}{\text{Degrees Arc} \times \text{Head Spacing} \times \text{Row Spacing}} \quad Pr = \frac{\text{m}^3/\text{hr (for any arc)} \times 360,000}{\text{Degrees of arc} \times \text{Head spacing (m)} \times \text{Row Spacing (m)}}$$

$$\text{Where:} \quad Pr = \frac{\text{l/min (for any arc)} \times 21,600}{\text{Degrees of arc} \times \text{Head spacing (m)} \times \text{Row Spacing (m)}} \text{ mm/hr}$$

Pr = precipitation rate in inches per hour
 GPM = flow for a given sprinkler of any arc, in gallons per minute
 Degrees Arc = the arc of the given sprinkler in degrees
 Head Spacing = the space between the heads in a row, in feet
 Row Spacing = the space between rows of heads, in feet
 34650 = constant for conversion of area and flow into common units

Example: What is the precipitation rate for a 270 degree sprinkler with 6.8 gpm spaced at 28' by 30'?

$$Pr = \frac{34,650 \times 6.8}{270 \times 28 \times 30} \quad Pr = 1.04 \text{ in./hr.}$$

Precipitation Rate - Method #2 - Total Area Method

$$Pr = \frac{96.25 \times \text{Total GPM}}{\text{Total Area}} \quad \left(Pr = \frac{\text{Total m}^3/\text{hr} \times 1,000}{\text{Total Area (m}^2)} = \text{mm/hr} \right) \quad \left(Pr = \frac{\text{Total l/min} \times 60}{\text{Total Area (m}^2)} = \text{mm/hr} \right)$$

Where:
 Pr = precipitation rate in inches per hour
 Total GPM = total flow from all sprinklers in the given area in gallons per minute
 Total Area = the given irrigated area in square feet
 96.25 = constant for conversion of area and flow into common units

Example: What is the average precipitation rate for a section of turf 325' by 80' if the total flow from all sprinklers in the area is 112 gpm.

$$Pr = \frac{96.25 \times 112}{(325 \times 80)} \quad Pr = 0.41 \text{ in./hr.}$$

SPRINKLER RUN TIME

The sprinkler run time formula calculates the number of minutes required to apply enough water to replace the water lost by evapotranspiration for a specific crop irrigated with a system at a particular precipitation rate and efficiency.

$$T = \frac{60 \times Et_o \times K_c}{Pr \times E_a}$$

Where:
 T = sprinkler run time in minutes
 Et_o = reference evapotranspiration rate, in inches
 K_c = crop coefficient, percent
 Pr = precipitation rate of the area, in inches per hour
 E_a = application efficiency of the system, percent
 60 = Constant for conversion of area, flow, inches per hour and inches per day into common units

Example: Determine the sprinkler run time for an athletic field with an accumulated Et_o of 0.45 inches (0.15"/day for 3 days) and a crop coefficient for the warm season turf of 0.70. The sprinkler precipitation rate is 0.50 in./hr. with an application efficiency of 75%.

$$T = \frac{60 \times 0.45 \times 0.70}{0.50 \times 0.75} \quad T = 50.4 \text{ min.}$$

Hunter®

Hunter Industries Incorporated • The Irrigation Innovators

1940 Diamond Street • San Marcos, California 92069 • TEL: (1) 760-744-5240 • FAX: (1) 760-744-7461
www.HunterIndustries.com

© 2003 Hunter Industries Incorporated

P/N 700128 LIT-229 2/03